

# Aethalometer AE33

Data handling



## Outline

- AE33 data capture
- AE33 data structure
- Verification
- “Loading effect compensation”
- Data presentation
- Advanced data analysis
- CAAT - Carbonaceous Aerosol Analysis Tool
- Questions



AEROSOL  
MAGEE SCIENTIFIC

## **AE33 data capture**

# Data management



Database

Data files

Data streaming



## Database

HOME	OPERATION	DATA	ABOUT
TABLE	EXPORT		
Free space: 19 year(s) and 24 day(s) left			
<input checked="" type="checkbox"/> Delete Oldest If Full			DeleteCFdata
From	01 Jan 2003	To	21 Aug 2018
			Restore settings
ExportToUSB	Copy DB to USB		Basic settings

### Primary data system

Database can be downloaded when measurements are stopped.

# Data files

HOME OPERATION DATA ABOUT

TABLE EXPORT

Free space: 19 year(s) and 24 day(s) left

Delete Oldest If Full

From 01 Jan 2003 To 21 Aug 2018

DeleteCFdata

Restore settings

ExportToUSB Copy DB to USB Basic settings

Data can be downloaded without stopping the measurement.

File Name	File Type	Size
AE_SETUP_AE33-S07-00633.XML	XML Document	5 KB
AE33_AE33-S07-00633_20180319.dat	DAT File	531 KB
AE33_AE33-S07-00633_20180320.dat	DAT File	531 KB
AE33_AE33-S07-00633_20180321.dat	DAT File	539 KB
AE33_AE33-S07-00633_20180322.dat	DAT File	536 KB
AE33_AE33-S07-00633_20180323.dat	DAT File	542 KB
AE33_AE33-S07-00633_20180324.dat	DAT File	542 KB
AE33_AE33-S07-00633_20180325.dat	DAT File	546 KB
AE33_AE33-S07-00633_20180326.dat	DAT File	557 KB
AE33_AE33-S07-00633_20180327.dat	DAT File	536 KB
AE33_AE33-S07-00633_20180328.dat	DAT File	532 KB
AE33_AE33-S07-00633_20180329.dat	DAT File	533 KB
AE33_AE33-S07-00633_20180330.dat	DAT File	529 KB
AE33_AE33-S07-00633_20180331.dat	DAT File	521 KB
AE33_AE33-S07-00633_20180401.dat	DAT File	522 KB
AE33_AE33-S07-00633_20180402.dat	DAT File	524 KB
AE33_AE33-S07-00633_20180403.dat	DAT File	515 KB
AE33_AE33-S07-00633_20180404.dat	DAT File	880 KB
AE33_log_AE33-S07-00633_20180318.dat	DAT File	4 KB
AE33_log_AE33-S07-00633_20180321.dat	DAT File	1 KB
AE33_log_AE33-S07-00633_20180323.dat	DAT File	1 KB
AE33_log_AE33-S07-00633_20180403.dat	DAT File	1 KB
AE33_log_AE33-S07-00633_20180404.dat	DAT File	2 KB
CT_AE33-S07-00633_20180318_155903.dat	DAT File	1 KB
CT_AE33-S07-00633_20180404_162603.dat	DAT File	1 KB
ST_AE33-S07-00633_20180318_152803.dat	DAT File	1 KB

Setup file

Daily data files

Log files

Clean print

Stability test

# Setup file (I)

HOME	OPERATION	DATA	ABOUT
GENERAL	ADVANCED	LOG	MANUAL
TimeBase	60	Start	Stop
Flow	2 LPM	Stability	Clean air
Flow Rep. Std.	AMCA	Verify flow	ND test
TA ATNmax	120	Leakage test	Inlet leakage
TAINT	12 h		
TATime	01 Jan 2003 00:02:47		
Time and Date	07 Oct 2020 07:29:35		
Time zone	(GMT) Coordinated Universal Time		
Auto Clean Air	Weekly		
	SUN 00:00:00		

HOME	OPERATION	DATA	ABOUT
GENERAL	ADVANCED	LOG	MANUAL
Status	12	Flow Σ (mlpm)	1999
Controller status	0	Flow1 (mlpm)	1924
Detector status	10	Pump (ref.val.)	331
LED status	10	Flow sensor Σ	325
TA status	0	Flow sensor 1	348
Tape sensor left	182	Chamber status	10
Tape sensor right	191	Chamber position	332
TapeAdvance left	268	Valve status	00000
ATNF1	10	Z	0.07
ATNF2	30	C	1.57
Warm up interval (min)	3	TA adjust (%)	0
Firmware version	518		
Software version	1.4.1.1		
Instrument IP	172.16.0.90		
Data center IP	172.16.0.2		
Serial number	AE33-S04-00378		

```

<data>
<name>Aethalometer</name>
<manufacturer>Magee Scientific</manufacturer>
<!-- Instrument serial number -->
<SerialNumber>AE33-S07-00633</SerialNumber>
<!-- Model number -->
<ModelNo>AE33</ModelNo>
<!-- Language used for all text in AE software! -->
<language>EN</language>
<!-- Number of channels 7 wavelengths (from IR to UV) -->
<NoOfChannels>7</NoOfChannels>
<!-- About -->
<SetupStartTime>2017/10/11 08:51:52</SetupStartTime>
<SetupEndTime></SetupEndTime>
<DateFormat>1</DateFormat>
<MeasureTimeStamp>1</MeasureTimeStamp>
<!-- Preset value for pump -->
<PumpPresetValue>585</PumpPresetValue>
<!-- Set Flow in mlpm; 2000, 3000, 4000, 5000 -->
<FlowSet>5000</FlowSet>
<!-- TimeBase interval; can be 1, 60 seconds -->
<TimeBase>60</TimeBase>
<!-- sigma value for channel 1 -->
<SG1>18.47</SG1>
<!-- sigma value for channel 2 -->
<SG2>14.54</SG2>
<!-- sigma value for channel 3 -->
<SG3>13.14</SG3>
<!-- sigma value for channel 4 -->
<SG4>11.58</SG4>
<!-- sigma value for channel 5 -->
<SG5>10.35</SG5>
<!-- sigma value for channel 6 -->
<SG6>7.77</SG6>
<!-- sigma value for channel 7 -->
<SG7>7.19</SG7>
<!-- Spot size in cm2 -->
<Area>0.785</Area>
<!-- Maximum attenuation before tape advance -->
<AtnMAX>120</AtnMAX>
<!-- Condition when Tape Advance starts; 1 - ATNmax, 2 - time interval (every n-hours), 3 - certain time of day -->
<TAType>1</TAType>
<!-- TapeAdvanceInterval is unit in hours between 2 tape advance -->
<TapeAdvanceInterval>12</TapeAdvanceInterval>
<!-- TapeAdvanceTime is time of next tape advance occurrence! -->
<TapeAdvanceTime>1/1/2003 12:02:47 AM</TapeAdvanceTime>
<!-- TapeAdvanceCount is overall number of TA counts! -->
<TapeAdvanceCount>62</TapeAdvanceCount>
<!-- WarmUpInterval is time (in minutes) after TA of Clean Air flow -->
<WarmUpInterval>3</WarmUpInterval>

```

Setup start and end time

Mass absorption cross section (m<sup>2</sup>/g)

# Setup file (II)

HOME OPERATION DATA ABOUT

GENERAL ADVANCED LOG NETWORK MANUAL

TimeBase 60 s Start Stop

Flow 2 LPM

Flow Rep. Std. AMCA Stability Clean air

P: 101325 Pa T: 21.11 °C

TA ATNmax 120 Verify flow ND test

TAINT 12 Leakage test Inlet leakage

TATime 01 Jan 2003 00:02:47

Time and Date 07 Oct 2020 07:29:35

Time zone (GMT) Coordinated Universal Time DST

Auto Clean Air Weekly Monthly None NTP Shut down

SUN 00:00:00 GPS

```
<FlowFormulaA0>-2381.79516601562</FlowFormulaA0>
<FlowFormulaA1>-2939.44995117187</FlowFormulaA1>
<FlowFormulaA2>-3000</FlowFormulaA2>
<FlowFormulaB0>13.2281427383423</FlowFormulaB0>
<FlowFormulaB1>14.2686452865601</FlowFormulaB1>
<FlowFormulaB2>16</FlowFormulaB2>
<FlowFormulaC0>-0.00122687732800841</FlowFormulaC0>
<FlowFormulaC1>-0.00183068192563951</FlowFormulaC1>
<FlowFormulaC2>-0.003</FlowFormulaC2>
<FlowFormulaD>184.300888061523</FlowFormulaD>
<FlowFormulaE>0.0780352279543877</FlowFormulaE>
<FlowFormulaF>6.74876275752467E-07</FlowFormulaF>
```

Flow meter calibration

```
<TapeOffsetValid>0</TapeOffsetValid>
<TapeRightFormulaK>1.13398694992065</TapeRightFormulaK>
<TapeRightFormulaN>-36.6666679382324</TapeRightFormulaN>
<TapeLeftFormulaK>1.18666660785675</TapeLeftFormulaK>
<TapeLeftFormulaN>-80.3333282470703</TapeLeftFormulaN>
```

Tape sensor calibration

```
<Zeta>0.01</Zeta>
<C>1.39</C>
<ATNf1>10</ATNf1>
<ATNf2>30</ATNf2>
<Kmax>0.015</Kmax>
<Kmin>-0.005</Kmin>
```

Leakage and multiple scattering parameter

```
<Aff>1</Aff>
<Abb>2</Abb>
<k0>0.0001</k0>
<k1>0.0001</k1>
<k2>0.0001</k2>
<k3>0.0001</k3>
<k4>0.0001</k4>
<k5>0.0001</k5>
<k6>0.0001</k6>
```

AAE for source apportionment

HOME OPERATION DATA ABOUT

GENERAL ADVANCED LOG MANUAL

Status 12 Flow Σ (mlpm) 1999 Sigma\_Air (Å) LED err Detector err

Controller status 0 Flow1 (mlpm) 1924 Ch1 18.47 0 0

Detector status 10 Pump (ref.val.) 331 Ch2 14.54 0 0

LED status 10 Flow sensor Σ 325 Ch3 13.14 0 0

TA status 0 Flow sensor 1 348 Ch4 11.58 0 0

Tape sensor left 182 Chamber status 10 Ch5 10.35 0 0

Tape sensor right 191 Chamber position 332 Ch6 7.77 0 0

TapeAdvance left 268 Valve status 00000 Ch7 7.19 0 0

ATNf1 10 Z 0.07 Kmax 0.015 Aff 1 Measure time stamp Before After

ATNf2 30 C 1.57 Kmin -0.005 Abb 2 Home display UVPM Print BB

Warm up interval (min) 3 TA adjust (%) 0 Display ON Saver Auto OFF

Firmware version 518 External ID 1 BH param ID 1

Software version 1.4.1.1

Instrument IP 172.16.0.90 FlowCal TapeSenAdj LED adjust

Data center IP 172.16.0.2 8000 Change Tape External device Update

Serial number AE33-S04-00378

```
<!-- Flow reporting standard -->
<FlowRepStd>0</FlowRepStd>
<!-- External Pressure -->
<P>101325</P>
<!-- External Temperature -->
<T>21.11</T>
```

Flow reporting standard

# Setup file (III)

HOME		OPERATION		DATA		ABOUT	
GENERAL		ADVANCED		LOG		NETWORK	
TimeBase	60 s	Start		Stop			
Flow	2 LPM	Stability		Clean air			
Flow Rep. Std.	AMCA	Verify flow		ND test			
P: 101325 Pa T: 21.11 °C							
TA ATNmax	120	Leakage test		Inlet leakage			
TAINT	12 h						
TATime	01 Jan 2003 00:02:47						
Time and Date	07 Oct 2020 07:29:35						
Time zone	(GMT) Coordinated Universal Time	<input type="checkbox"/> DST					
<input checked="" type="checkbox"/> Auto Clean Air	<input checked="" type="radio"/> Weekly <input type="radio"/> Monthly <input type="radio"/> None <input checked="" type="radio"/> NTP	Shut down					
	SUN 00:00:00	<input type="checkbox"/> GPS					

```

<Device1>0</Device1>
  <!-- External device on COM2-->
<Device2>0</Device2>
  <!-- External device on COM3-->
<Device3>0</Device3>
  <!-- Network connection-->
<IPAddress>127.0.0.1</IPAddress>
<IPport>8001</IPport>
<AutoConnect>0</AutoConnect>
  <!-- Auto test enabled 0-NO, 1-YES -->
<AutoTestEnabled>0</AutoTestEnabled>
  <!-- Auto test type - weekly = 0, monthly = 1-->
<AutoTestType>0</AutoTestType>
  <!-- Auto test day 1-SUN, 2-MON, 3-TUE, 4-WED, 5-
<AutoTestDay>1</AutoTestDay>
  <!-- Auto test Time-->
<AutoTestTime>1/1/2014 12:00:00 AM</AutoTestTime>
  <!-- HomeInfo 0 - UVPM concentration, 1 - Display Biomass Burning(%)-->
<HomeInfo>0</HomeInfo>
  <!-- Display settings - 0 - ON, 1 - Screen Saver, 2 - Auto OFF-->
<Display>1</Display>
  <!-- Timezone settings, DST -->
<TimeZone>Coordinated Universal Time</TimeZone>
<DaylightSavingTime>0</DaylightSavingTime>
<ExternalID>1</ExternalID>
<BHparamID>1</BHparamID>
<TimeSync>1</TimeSync>
<TapeAdvanceAdjust>10</TapeAdvanceAdjust>
  
```

Connected External devices

Network information

Automatic Clean Air Test settings

Home Display settings

Time Zone, DST

HOME		OPERATION		DATA		ABOUT	
GENERAL		ADVANCED		LOG		MANUAL	
Status	12	Flow Σ (mlpm)	1999	Sigma_Air (λ)	LED err	Detector err	
Controller status	0	Flow1 (mlpm)	1924	Ch1	18.47	0	0
Detector status	10	Pump (ref.val.)	331	Ch2	14.54	0	0
LED status	10	Flow sensor Σ	325	Ch3	13.14	0	0
TA status	0	Flow sensor 1	348	Ch4	11.58	0	0
Tape sensor left	182	Chamber status	10	Ch5	10.35	0	0
Tape sensor right	191	Chamber position	332	Ch6	7.77	0	0
TapeAdvance left	268	Valve status	00000	Ch7	7.19	0	0
ATNF1	10	Z	0.07	Kmax	0.015	Aff	1
ATNF2	30	C	1.57	Kmin	-0.005	Abb	2
Warm up interval (min)	3	TA adjust (%)	0	Measure time stamp	<input type="checkbox"/> Before <input checked="" type="checkbox"/> After		
Firmware version	518			Home display	<input type="checkbox"/> UVPM <input checked="" type="checkbox"/> Proc BB		
Software version	1.4.1.1			Display	<input type="checkbox"/> ON <input checked="" type="checkbox"/> Saver <input type="checkbox"/> Auto OFF		
Instrument IP	172.16.0.90			External ID	1	BH param ID	1
Data center IP	172.16.0.2	8000					
<input checked="" type="checkbox"/> NetworkEnabled	<input checked="" type="checkbox"/> IsConnected	<input checked="" type="checkbox"/> Online					
Serial number	AE33-S04-00378						

# Log file

```

AE33_log_AE33-S07-00633_20180318.dat - Notepad
File Edit Format View Help
18/Mar/2018 14:59:26 Instrument turned on.
18/Mar/2018 15:00:10 TapeAdvance procedure started.
18/Mar/2018 15:00:11 No data from NTP server.
18/Mar/2018 15:00:28 Manual stop.
18/Mar/2018 15:00:29 Tape Advance canceled.
18/Mar/2018 15:00:30 Instrument stopped.
18/Mar/2018 15:00:31 Stability test started.
18/Mar/2018 15:00:44 TapeAdvance procedure started.
18/Mar/2018 15:00:44 No data from NTP server.
18/Mar/2018 15:01:21 Tape Advance number: 70 Number of steps: 672
18/Mar/2018 15:08:00 ATN1zero(1): 12.7562 ATN2zero(1): 14.9146
18/Mar/2018 15:08:00 ATN1zero(2): 11.9675 ATN2zero(2): 13.5048
18/Mar/2018 15:08:00 ATN1zero(3): 13.0136 ATN2zero(3): 12.3156
18/Mar/2018 15:08:00 ATN1zero(4): 8.0098 ATN2zero(4): 8.2115
18/Mar/2018 15:08:00 ATN1zero(5): -3.6798 ATN2zero(5): -2.2164
18/Mar/2018 15:08:00 ATN1zero(6): -20.5618 ATN2zero(6): -21.1645
18/Mar/2018 15:08:00 ATN1zero(7): -12.9651 ATN2zero(7): -12.5349
18/Mar/2018 15:28:03 Instrument stopped.
18/Mar/2018 15:28:03 Stability test finished.
18/Mar/2018 15:28:03 Stability test report.
Serialnumber: AE33-S07-00633
Date and time: 18 Mar 2018 15:28:03
Duration: 20 min, Timebase: 1 sec, Flow: 0 mlpm

      AverageBC      PPBC      (ng/m3)
      Spot1  Spot2  Spot1  Spot2
Ch1    -17    4    175    401
Ch2    -18    -8    212    483
Ch3    -11    10    238    539
Ch4     -6    62    275    644
Ch5     4    75    303    646
Ch6    -47   -32    424    950
Ch7     0    86    429   1027

Result of stability test is acceptable.
18/Mar/2018 15:34:39 Clean air test started.
18/Mar/2018 15:34:42 TapeAdvance procedure started.
18/Mar/2018 15:34:42 No data from NTP server.
18/Mar/2018 15:34:57 Tape Advance number: 71 Number of steps: 657
18/Mar/2018 15:39:00 ATN1zero(1): 8.1682 ATN2zero(1): 10.5806
18/Mar/2018 15:39:00 ATN1zero(2): 9.7634 ATN2zero(2): 11.3057
18/Mar/2018 15:39:00 ATN1zero(3): 10.8303 ATN2zero(3): 10.2634
18/Mar/2018 15:39:00 ATN1zero(4): 5.7360 ATN2zero(4): 6.1537
18/Mar/2018 15:39:00 ATN1zero(5): -5.8885 ATN2zero(5): -4.3333
18/Mar/2018 15:39:00 ATN1zero(6): -22.7641 ATN2zero(6): -23.4787
18/Mar/2018 15:39:00 ATN1zero(7): -15.0758 ATN2zero(7): -14.8499

```

## Test reports

```
CT_AE33-S07-00633_20180318_155903.dat - Notepad
File Edit Format View Help
Clean air test report.
Serialnumber: AE33-S07-00633
Date and time: 18 Mar 2018 15:59:03
Duration: 20 min, Timebase: 1 sec, Flow: 5000 mlpm

      AverageBC      PPBC      (ng/m3)
      Spot1   Spot2   Spot1   Spot2
Ch1      28     -58     148     564
Ch2     -39     -79     185     715
Ch3     -14      24     225     774
Ch4      -1     176     241     844
Ch5       3     149     271     933
Ch6     -72     -67     380    1355
Ch7     -18      97     399    1330

Result of clean air test is acceptable.
```

## Data streaming

Rear view

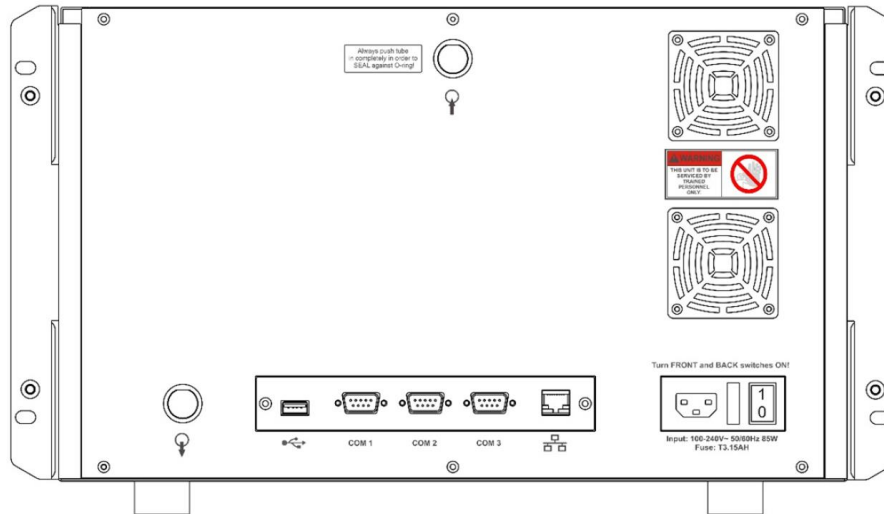

Data logger connected to the Serial port as an external device

- **Datalogger\_AE33\_protocol**
- **Datalogger\_BH\_protocol**
- **Datalogger\_Qair\_protocol**
  - communication protocol for digital links with 'Qair' air quality data acquisition stations
- **AE33\_data streaming**
  - the data line is the same as in the AE31

Communication program: **RealTerm**



## Data file structure

# Data file structure

Date(yyyy/MM/dd); Time(hh:mm:ss); Timebase; (Time zone setting is saved in the Setup file)

RefCh1; Sen1Ch1; Sen2Ch1; RefCh2; Sen1Ch2; Sen2Ch2; RefCh3; Sen1Ch3; Sen2Ch3;  
RefCh4; Sen1Ch4; Sen2Ch4; RefCh5; Sen1Ch5; Sen2Ch5; RefCh6; Sen1Ch6; Sen2Ch6;  
RefCh7; Sen1Ch7; Sen2Ch7;

Flow1; Flow2; FlowC; (mLPM)

Pressure(Pa); Temperature(°C); (p and T used for volumetric flow)

**BB(%);** (% of biomass burning BC)

ContTemp; SupplyTemp; **Status**; ContStatus; DetectStatus; LedStatus; ValveStatus;  
LedTemp;

BC11; BC12; BC1; BC21; BC22; BC2; BC31; BC32; BC3; BC41; BC42; BC4; BC51; BC52; BC5;  
BC61; BC62; **BC6**; BC71; BC72; BC7;

K1; K2; K3; K4; K5; K6; K7;

TapeAdvCount;

External devices

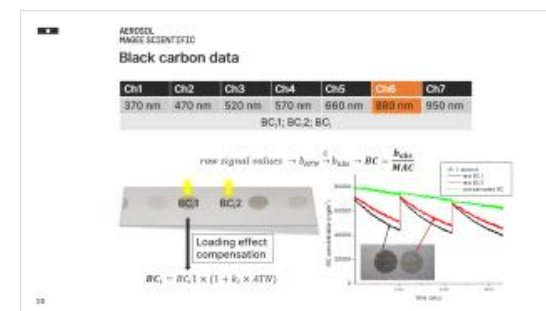
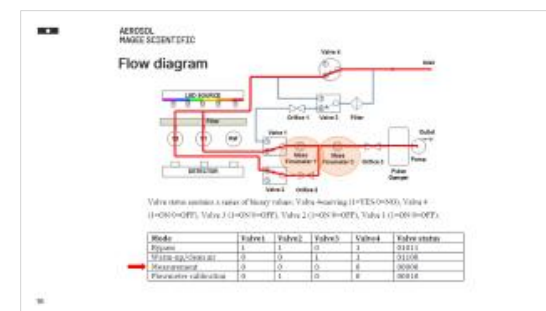
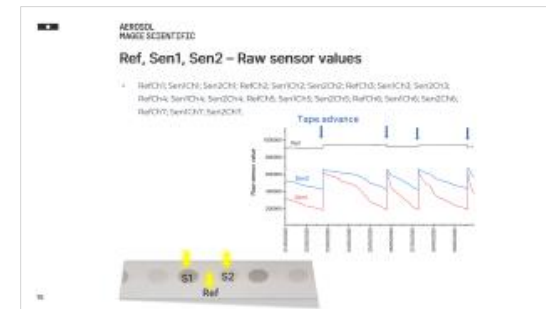

## Ref, Sen1, Sen2 – Raw sensor values

- RefCh1; Sen1Ch1; Sen2Ch1; RefCh2; Sen1Ch2; Sen2Ch2; RefCh3; Sen1Ch3; Sen2Ch3;  
RefCh4; Sen1Ch4; Sen2Ch4; RefCh5; Sen1Ch5; Sen2Ch5; RefCh6; Sen1Ch6; Sen2Ch6;  
RefCh7; Sen1Ch7; Sen2Ch7;

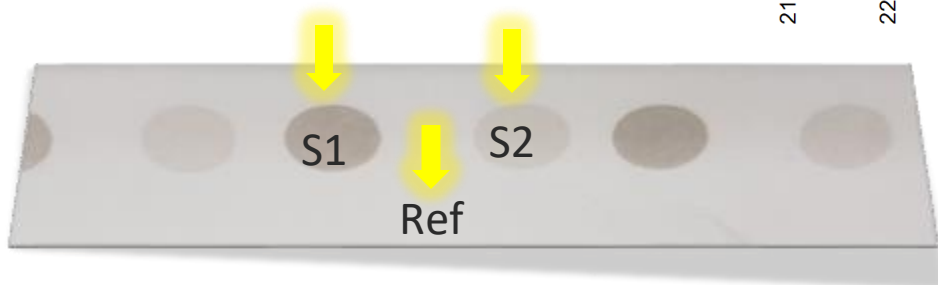
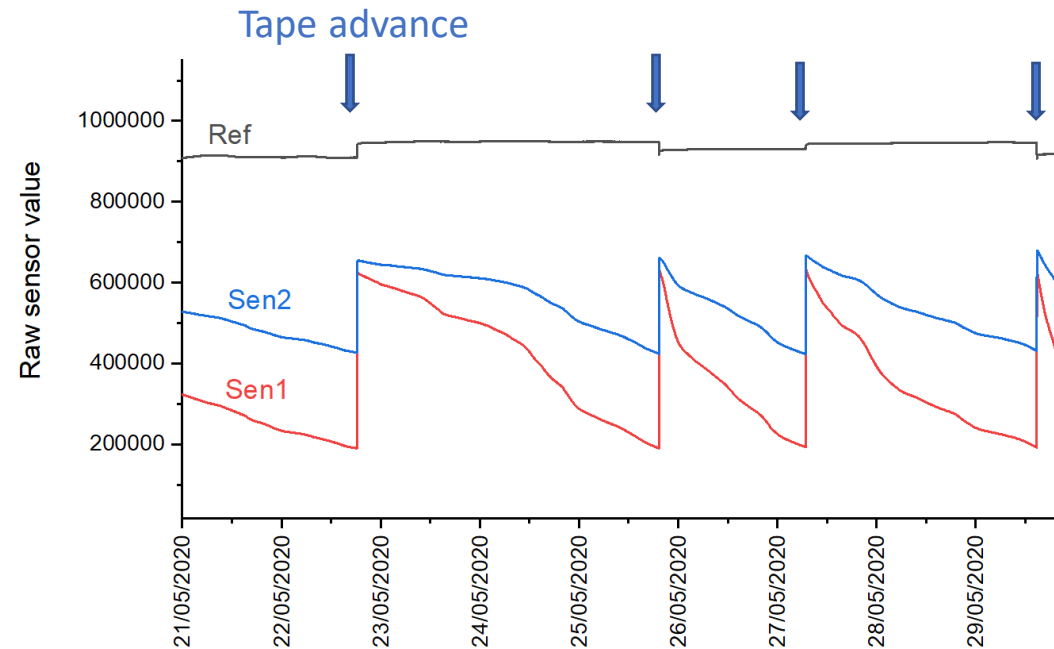

## Flow diagram

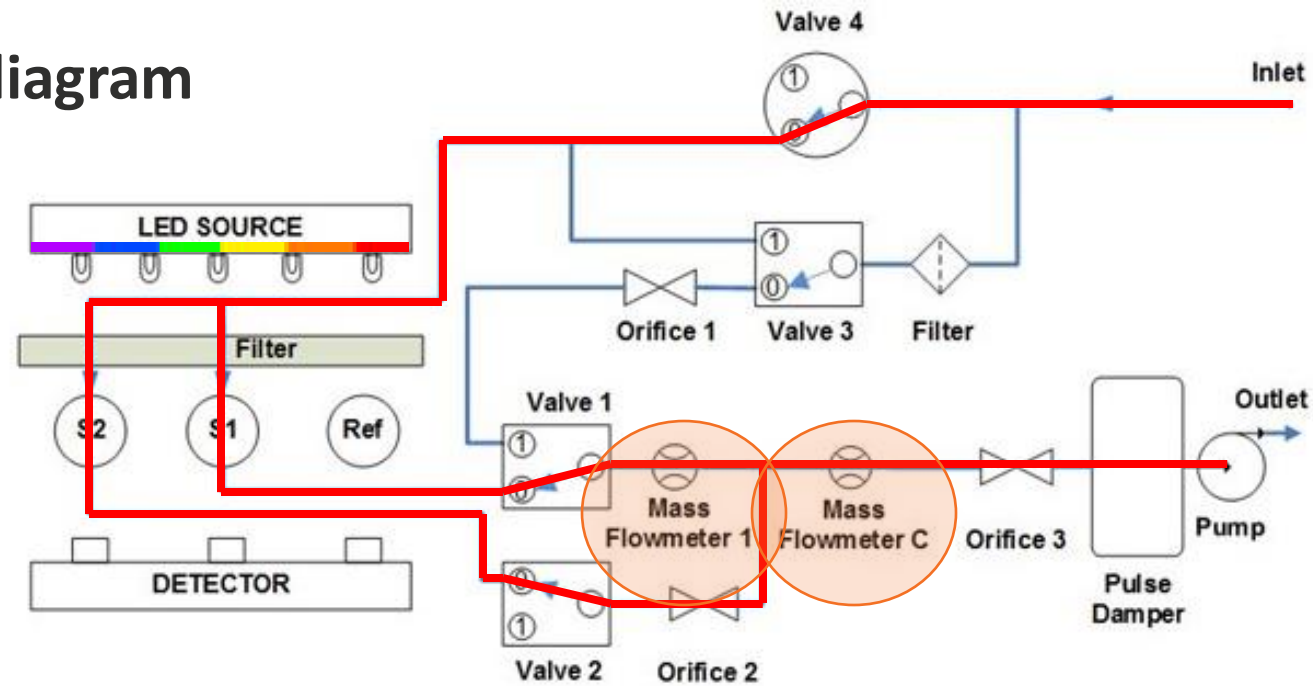

Valve status contains a series of binary values: Valve 4-moving (1=YES/0=NO), Valve 4 (1=ON/0=OFF), Valve 3 (1=ON/0=OFF), Valve 2 (1=ON/0=OFF), Valve 1 (1=ON/0=OFF).

Mode	Valve1	Valve2	Valve3	Valve4	Valve status
Bypass	1	1	0	1	01011
Warm-up/clean air	0	0	1	1	01100
Measurement	0	0	0	0	00000
Flowmeter calibration	0	1	0	0	00010



## Flow data

### the DualSpot™ method

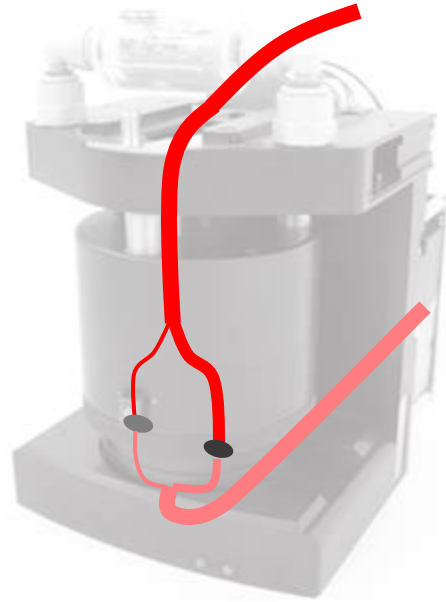

- Acceptable flow ratio  $F2/F1$  should be in range: **0.2 – 0.75** (warning Status: 4, 8, 12)
- Flow ratio changes slightly:
  - at different flows
  - different flow reporting standards.

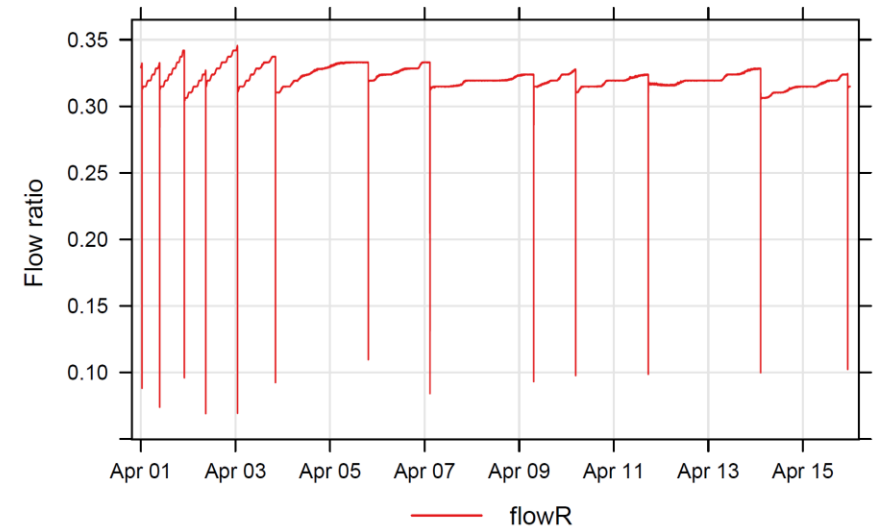
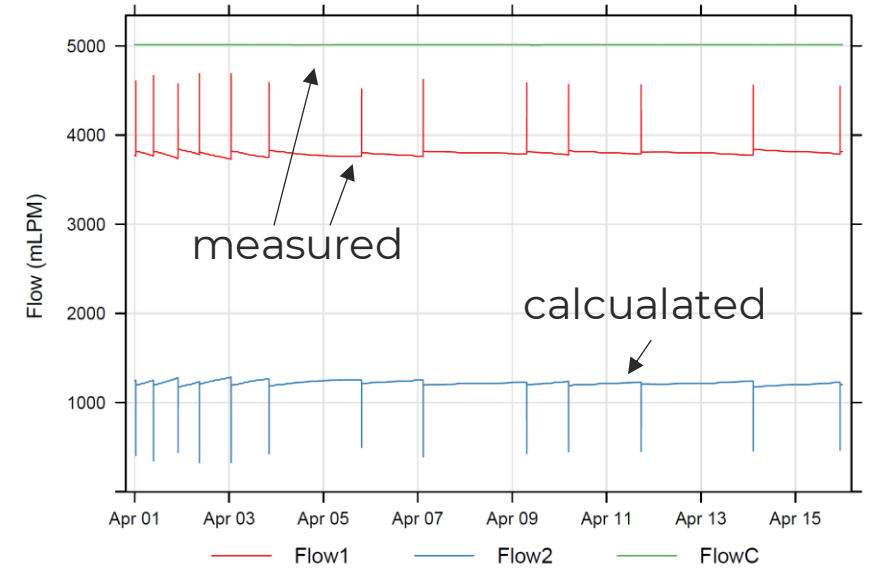

## Flow reporting standard

Sample flow is measured by a **mass flow meter** →  
adjusted in order to keep **volumetric flow stable**.

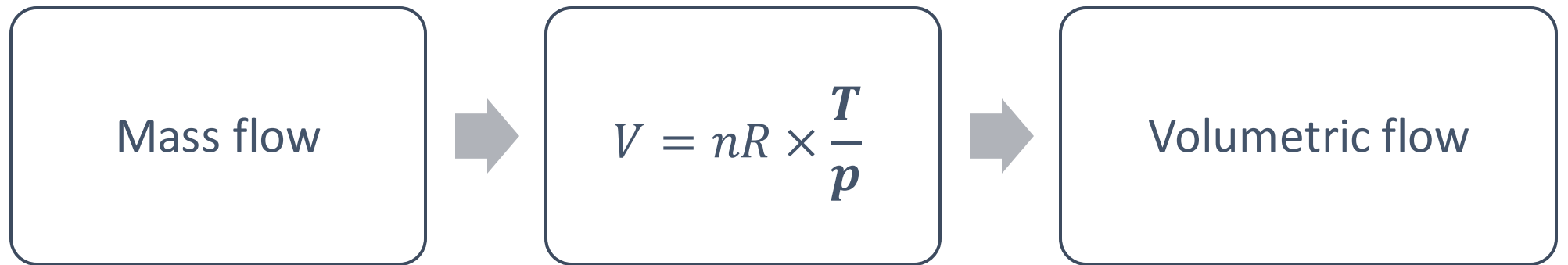

**Volumetric flow depends on the reported pressure & temperature.**  
**Different flowmeters and instruments use**  
***different flow reporting standards.***

It is always possible to recalculate to another flow reporting standard:

$$F_2 = F_1 \frac{T_2}{T_1} \frac{p_1}{p_2}$$

Temperature must be reported in **degrees K!**

## Flow reporting standard

HOME	OPERATION	DATA	ABOUT
GENERAL	ADVANCED	LOG	MANUAL
TimeBase	1 s	Start	Stop
Flow	5 LPM		
Flow Rep. Std.	AMCA		
	P: 101325 Pa T: 21.11 °C	Stability	Clean air
<input checked="" type="radio"/> TA ATNmax	120		
<input type="radio"/> TA INT	1 h	Verify flow	ND test
<input type="radio"/> TA Time	Aug 06 2014 12:50:17		
Time & Date	Aug 06 2014 12:14:00	<input type="checkbox"/> DST	
Time zone	(GMT) Coordinated Universal Time		
<input type="checkbox"/> Auto Clean Air			Shut down

Flow Rep. Std.

- AMCA (101325 Pa, 21.11°C)
- EPA (101325 Pa, 25°C)
- ISO (101325 Pa, 20°C)
- NIST (101325 Pa, 0°C)
- IUPAC (100000 Pa, 0°C)
- Manual
- Ambient

OK Cancel

Volumetric flow recalculation:

$$F_2 = F_1 \frac{T_2 p_1}{T_1 p_2}$$

## Black carbon data

Ch1	Ch2	Ch3	Ch4	Ch5	Ch6	Ch7
370 nm	470 nm	520 nm	570 nm	660 nm	880 nm	950 nm
BC <sub>i</sub> 1; BC <sub>i</sub> 2; BC <sub>i</sub>						

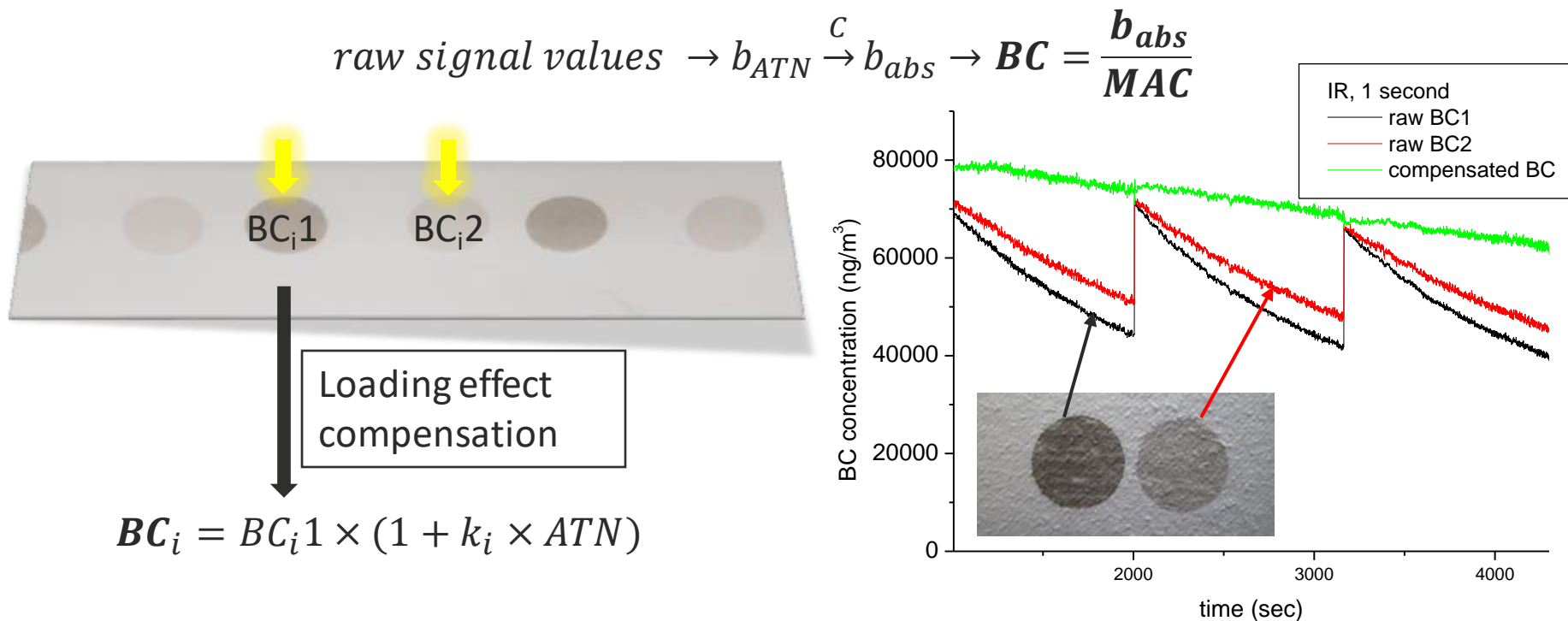



## Data verification

## Status warning / error

Status code is a sum of different status values

Status	Status relates to:	Status description
4, 8, 12	Flow	Flow too low/high, flow ratio, check history
16	LED source	LED calibration
32, 64		calibration error
128, 256	Filter tape	Tape warning
384		Tape error (end of tape)
512	Setup file	Setup warning
8192	External devices	Connection error
16384	Clean air test	Result not acceptable
32768	CF card	Problem saving data to CF card
65535	Database	Database bigger than 2*106 data lines

## Quality assurance

All quality assurance tests have a dedicated **Status code**

Status	Test	Frequency
1024	Stability test	1x / 6 month
2048	Clean air test	1x / month
16384	Result of automatic clean air test is not acceptable	
3072	Change tape procedure	
4096	Optical ND test	1x / year
6144	Leakage test	1x / 6 month
/	Flow verification	1x / 6 month

## Manual data checks

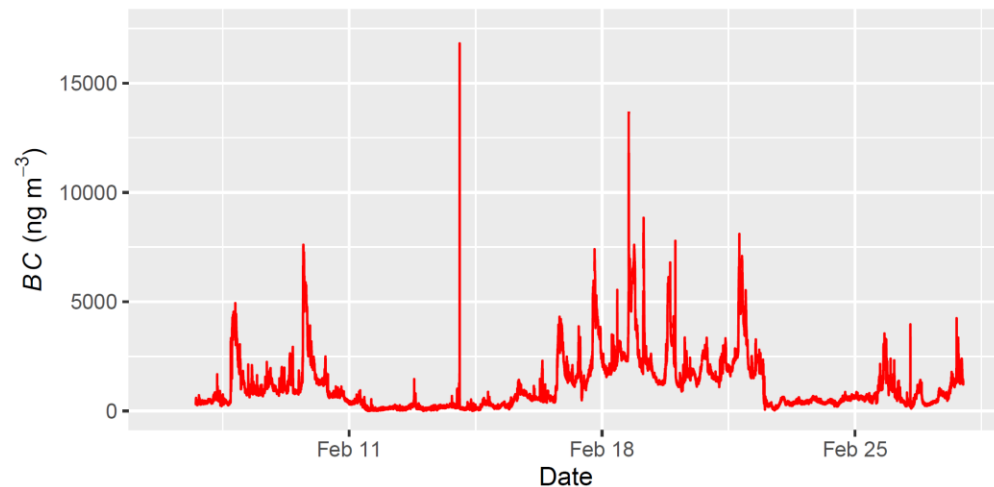

High noise:  
- flow not stable  
- dirty chamber

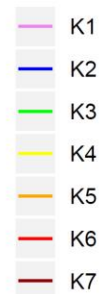
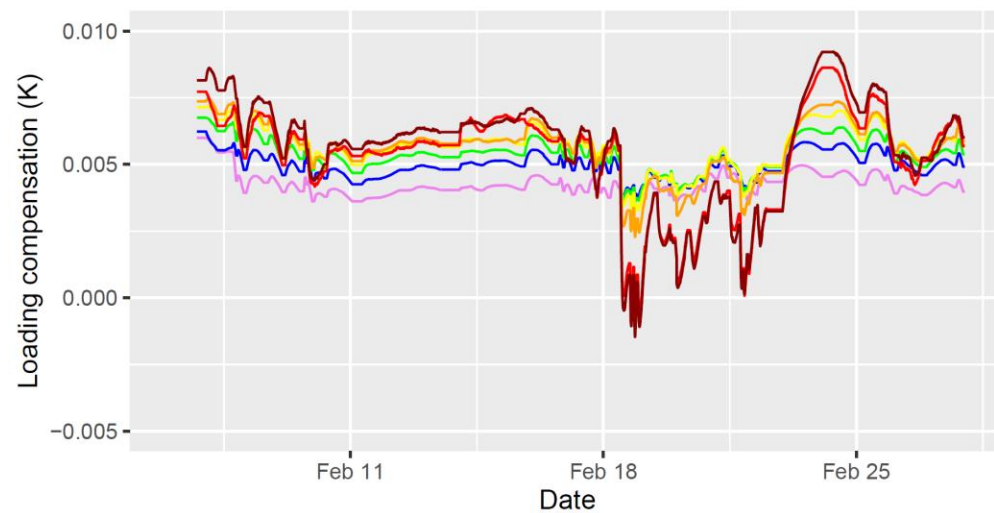

• Check filter loading effect  
compensation parameters (k)  
- Expected range:  $0 < k < 0.01$

## Manual data checks

Plot uncompensated BC from Spot1 (BC<sub>1</sub>) and Spot2 (BC<sub>2</sub>)

- different loading effect
- the same time variation

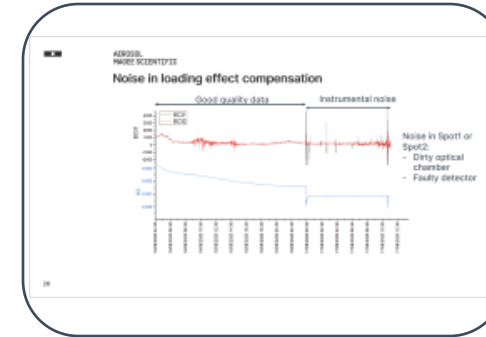
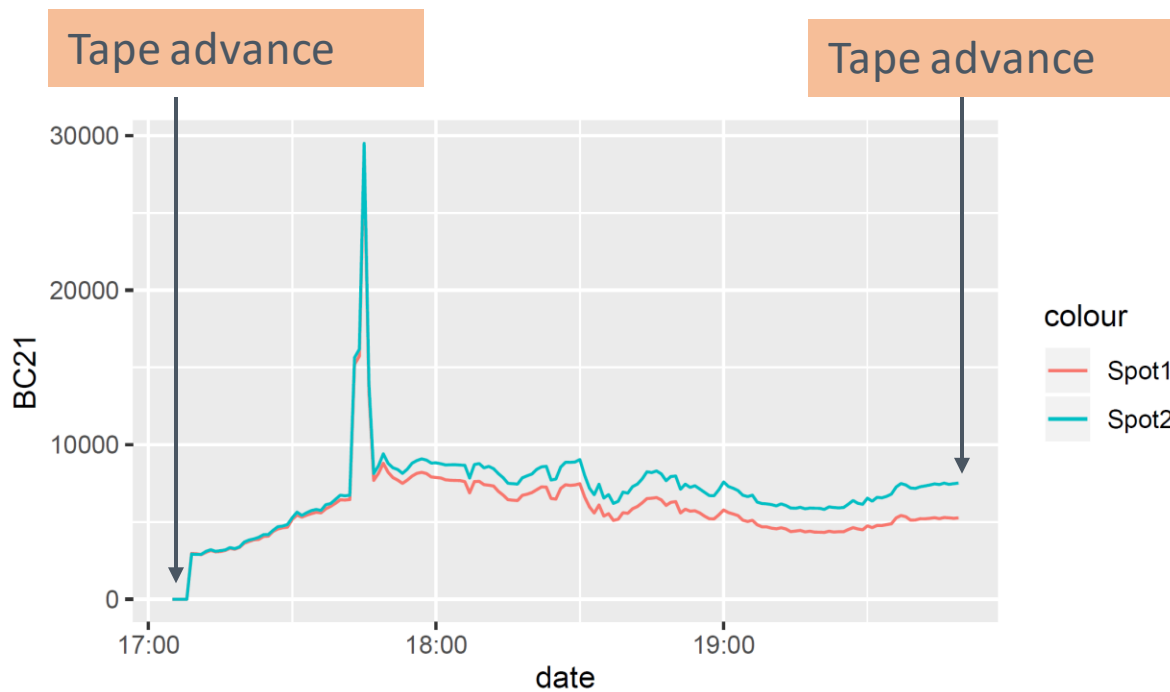

Noise in Spot1 or Spot2

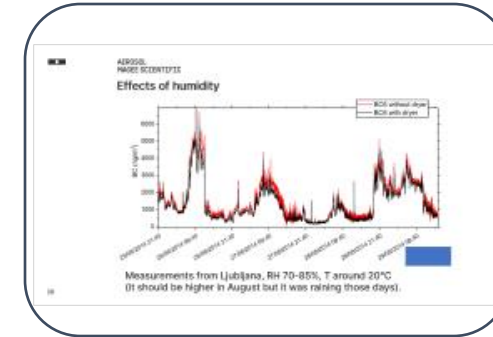

RH effect

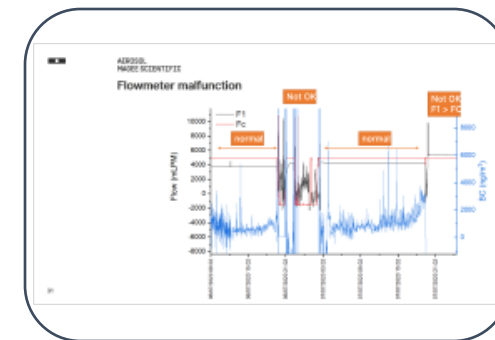

Flow meter malfunction

## Noise in loading effect compensation

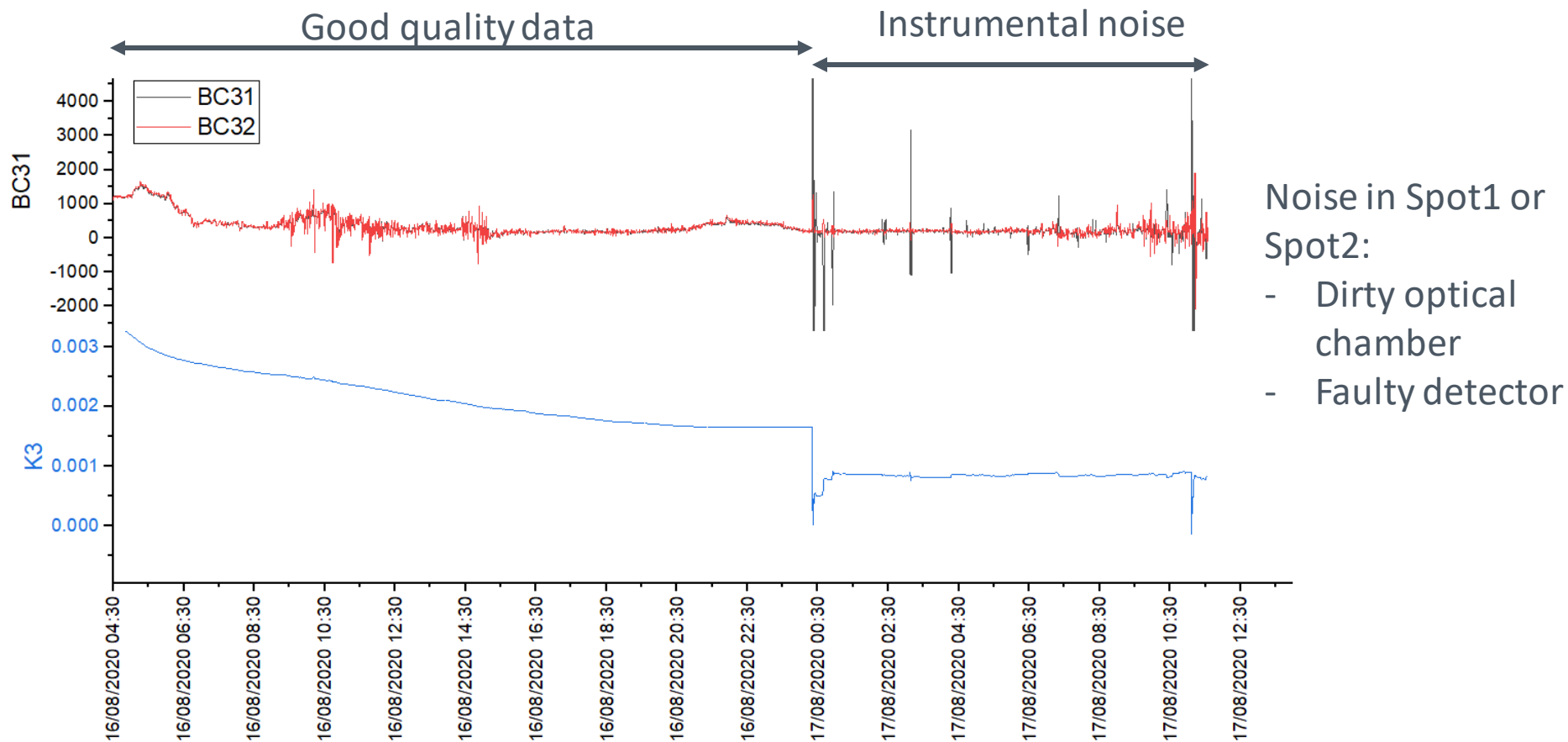

## Dirty optical chamber



## Effects of humidity

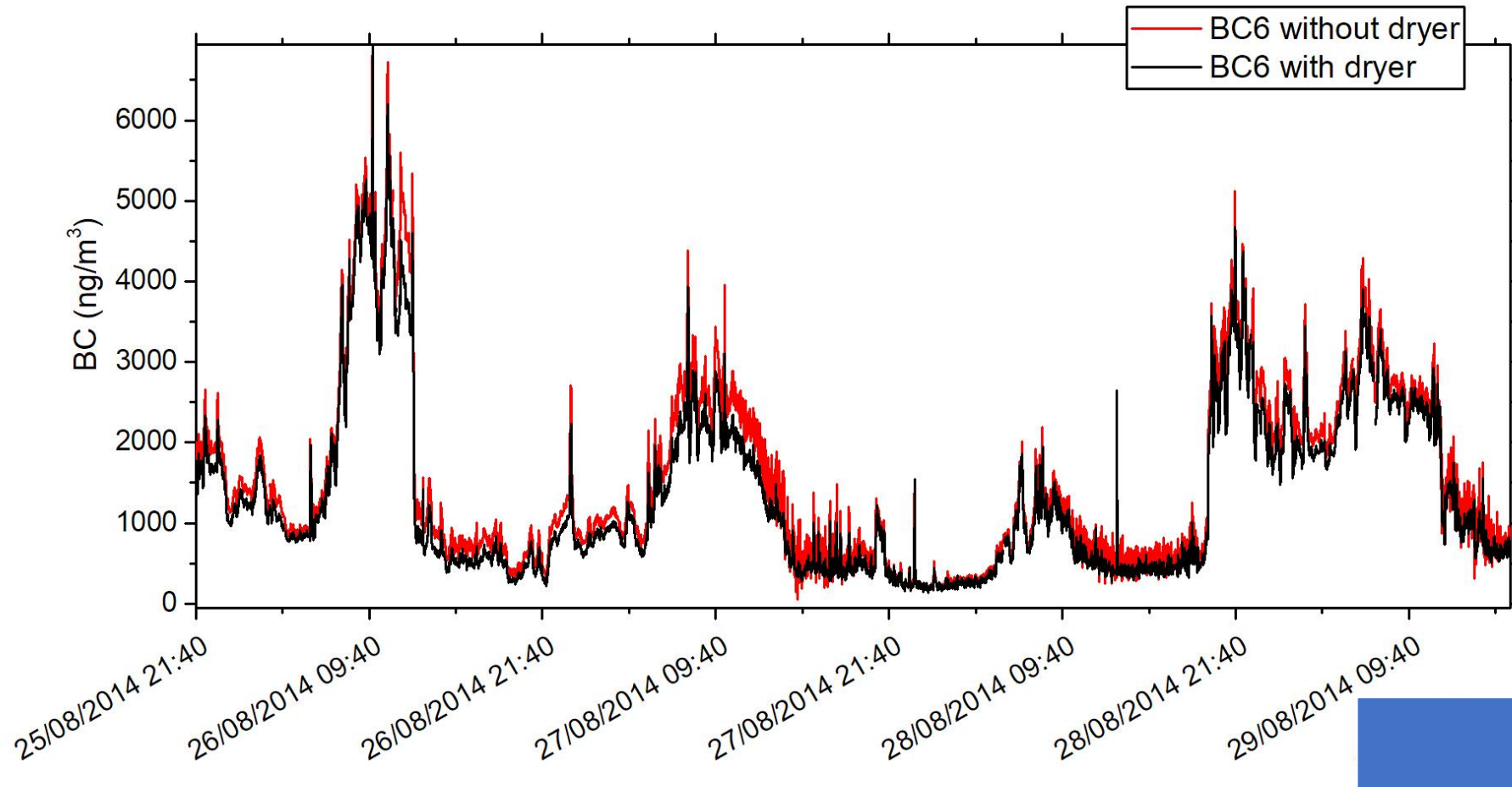

Measurements from Ljubljana, RH 70-85%, T around 20°C  
(it should be higher in August but it was raining those days).

## Influence of air-condition

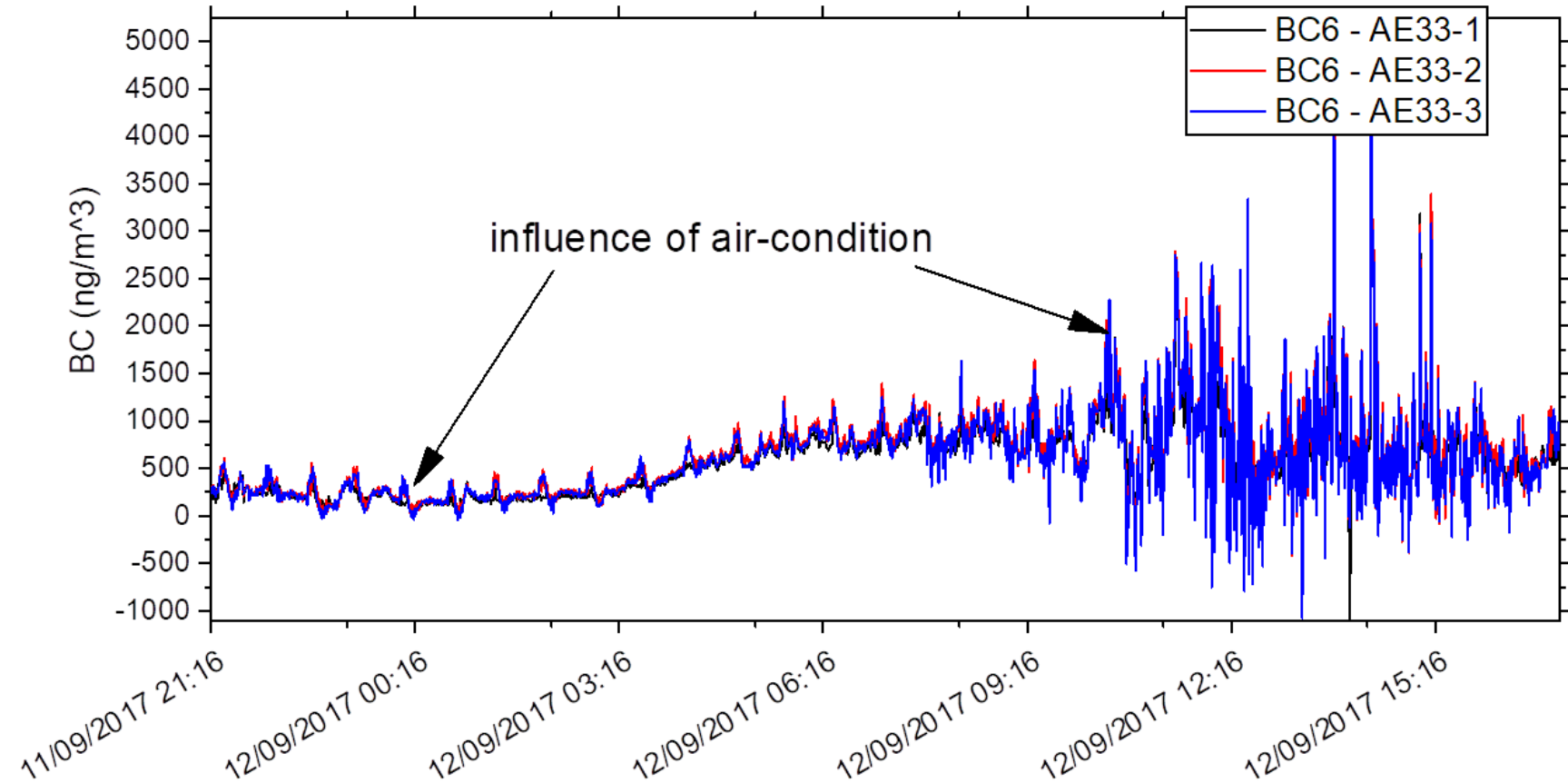

## Influence of air-condition

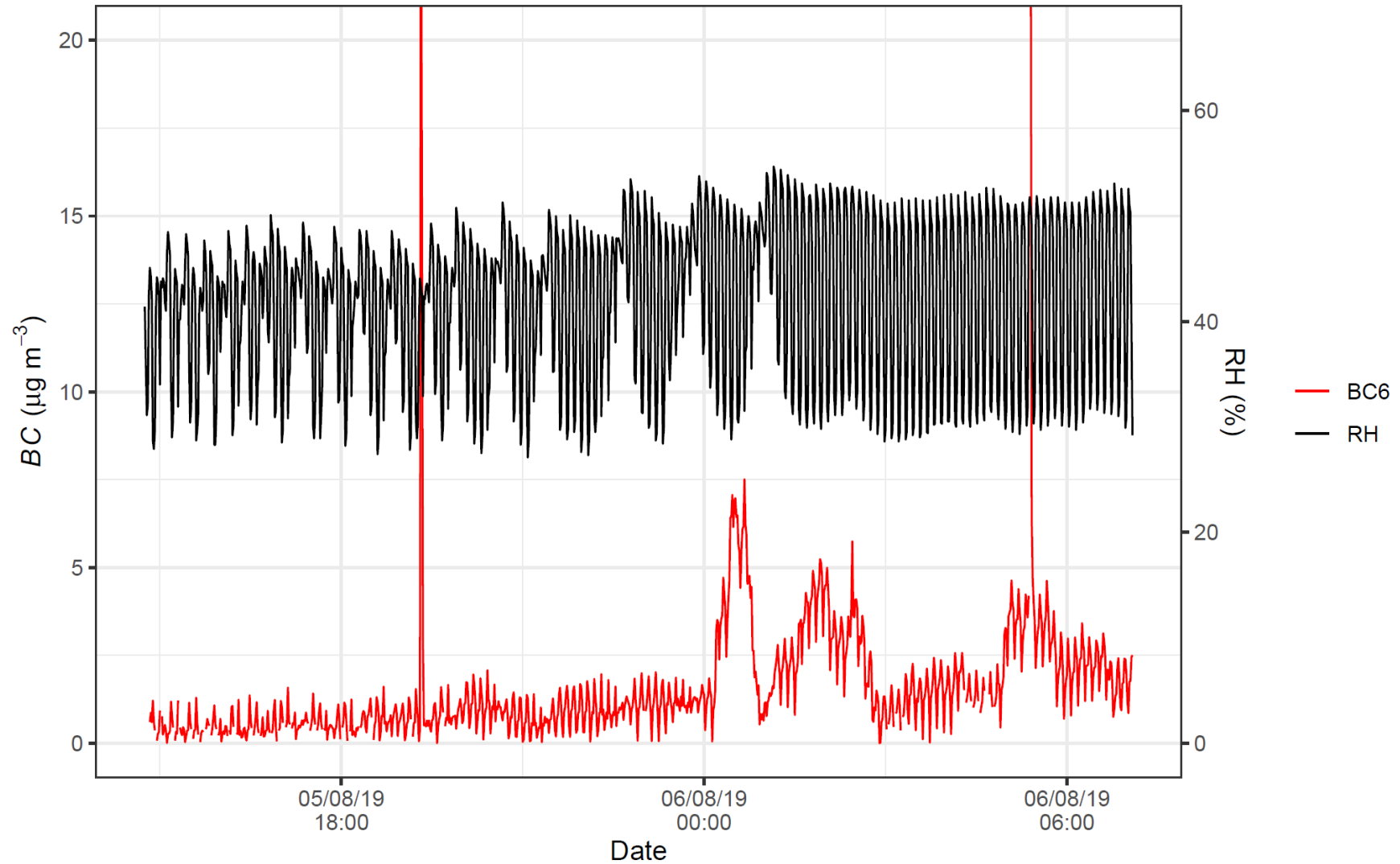

# Flowmeter malfunction

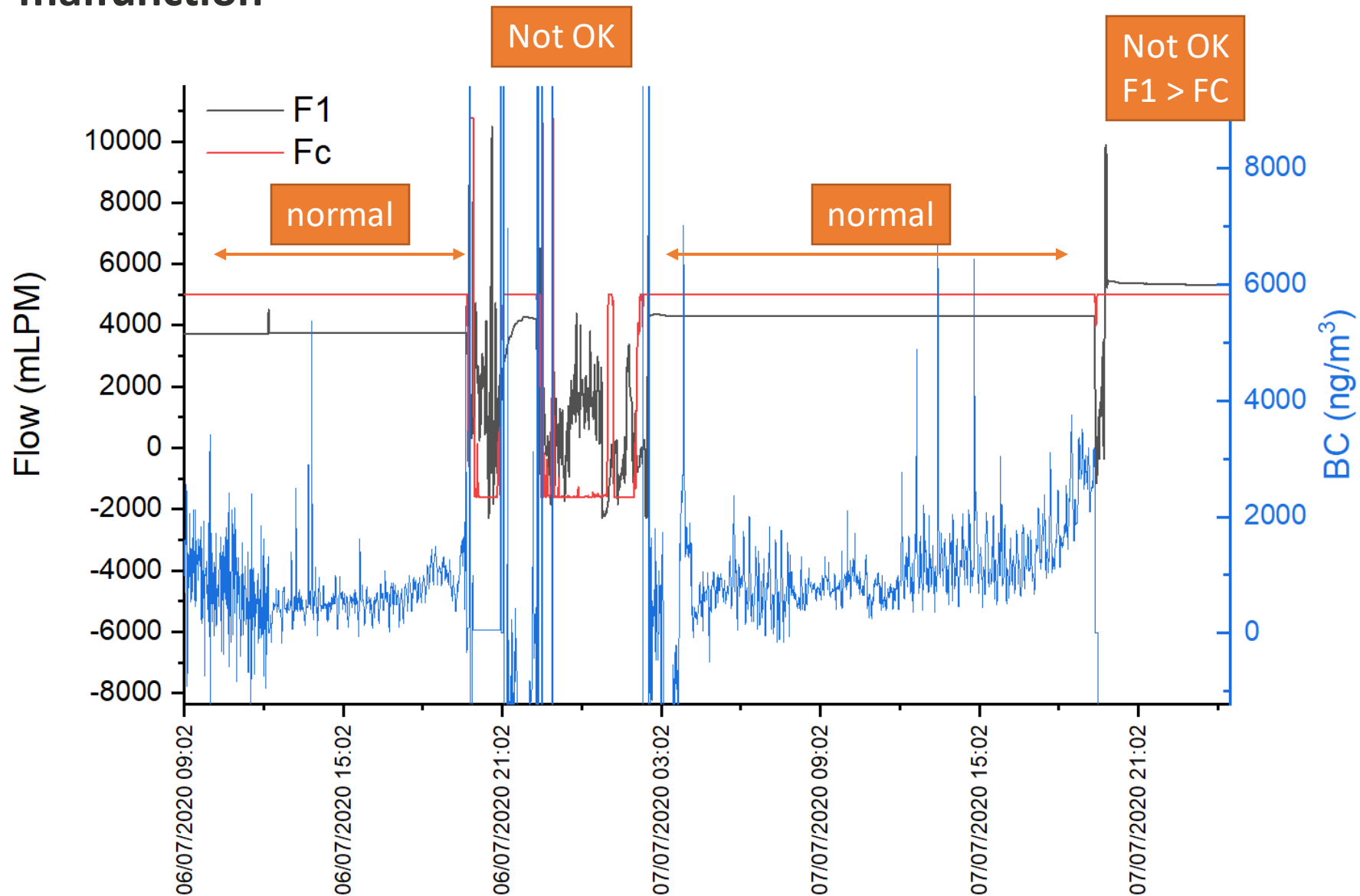



## Loading compensation

## Loading effect compensation

As the loading of particles on the filter increases, the existing particles may “shadow” the freshly-collected ones.



Linear reduction of the instrumental response due to loading of the filter fiber. Jump at the tape advance (Virkkula 2007)

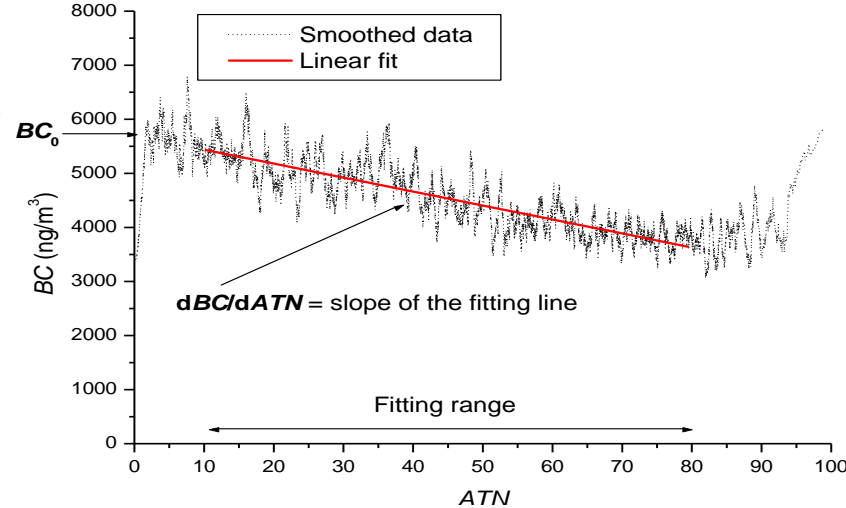
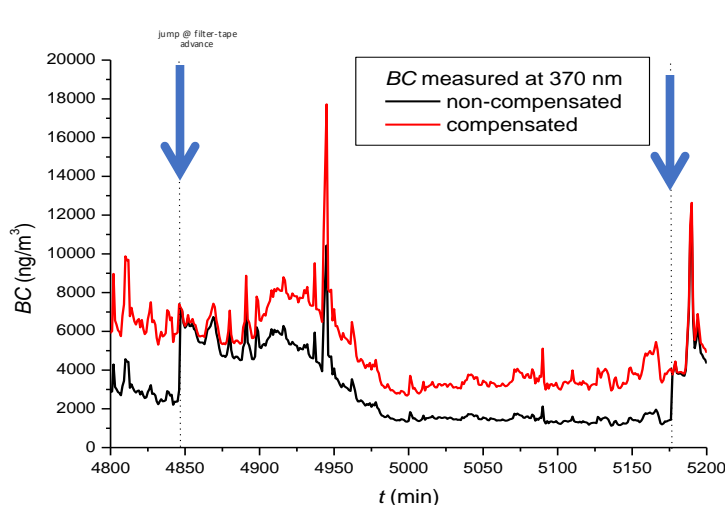

$$BC \text{ (reported)} = BC \text{ (zero loading)} \cdot \{ 1 - k \cdot ATN \}$$

- ambient data – no dependence of BC on ATN
- slope  $k$  variable: site, source, aerosol age, composition
- need to determine it dynamically – do not assume, rather **measure**

## Loading effect compensation - DualSpot method

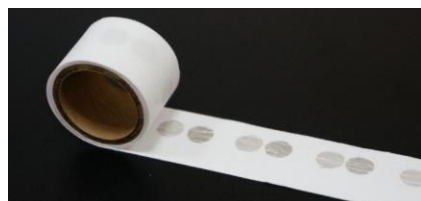
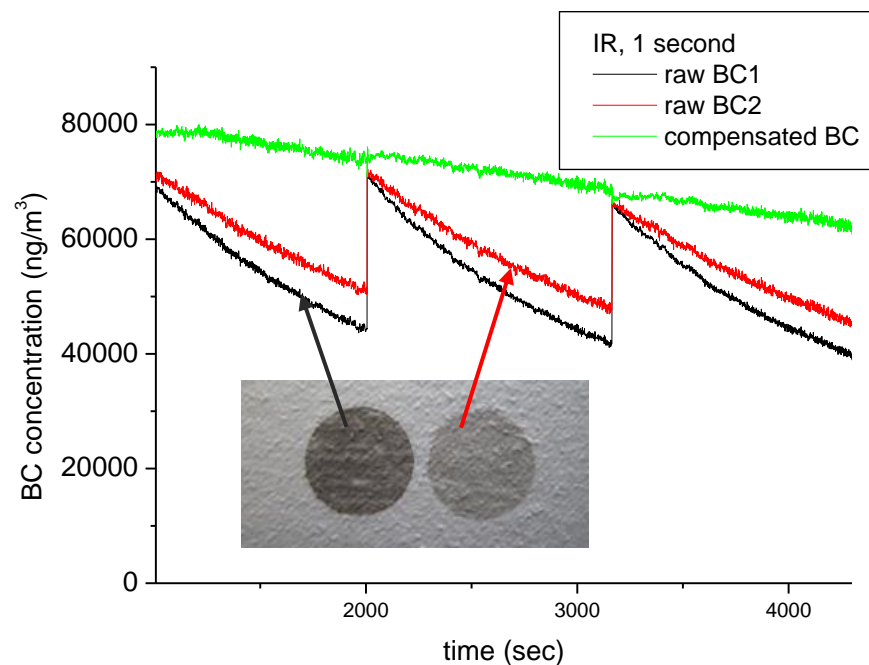
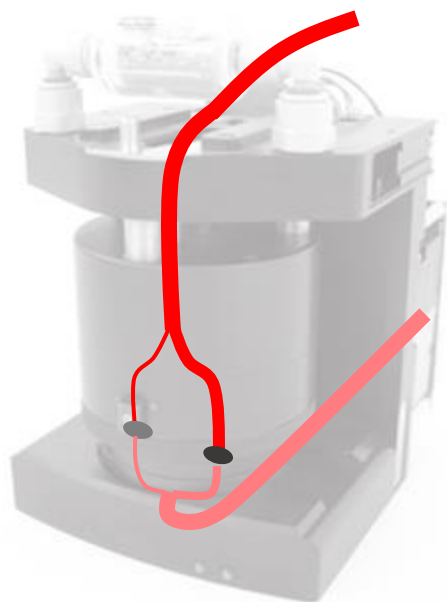

Two parallel spots with different flow, therefore different loading and attenuation.



Calculate loading compensated **BC** and **k**!

## Loading effect compensation – DualSpot method

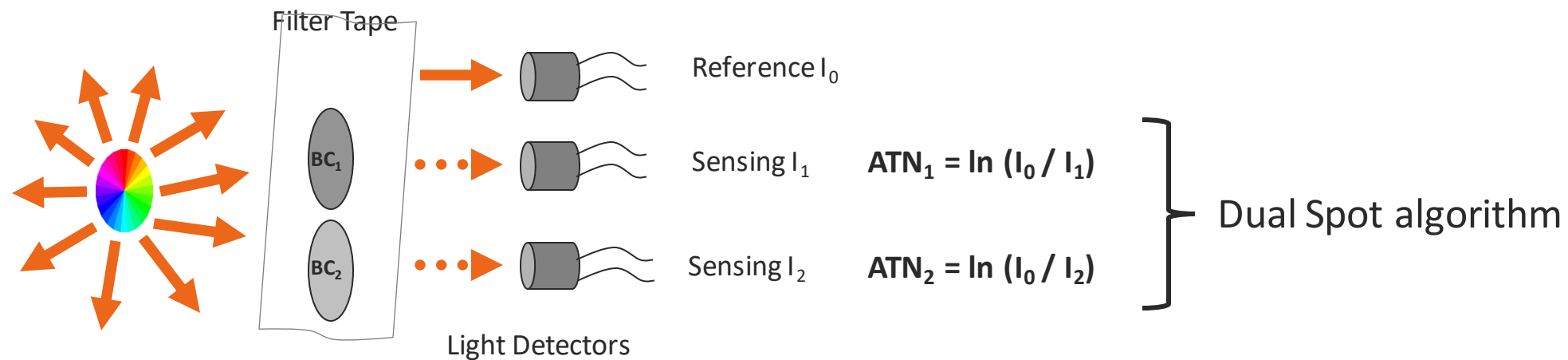

Two parallel spots with different flow -> different loading and attenuation.

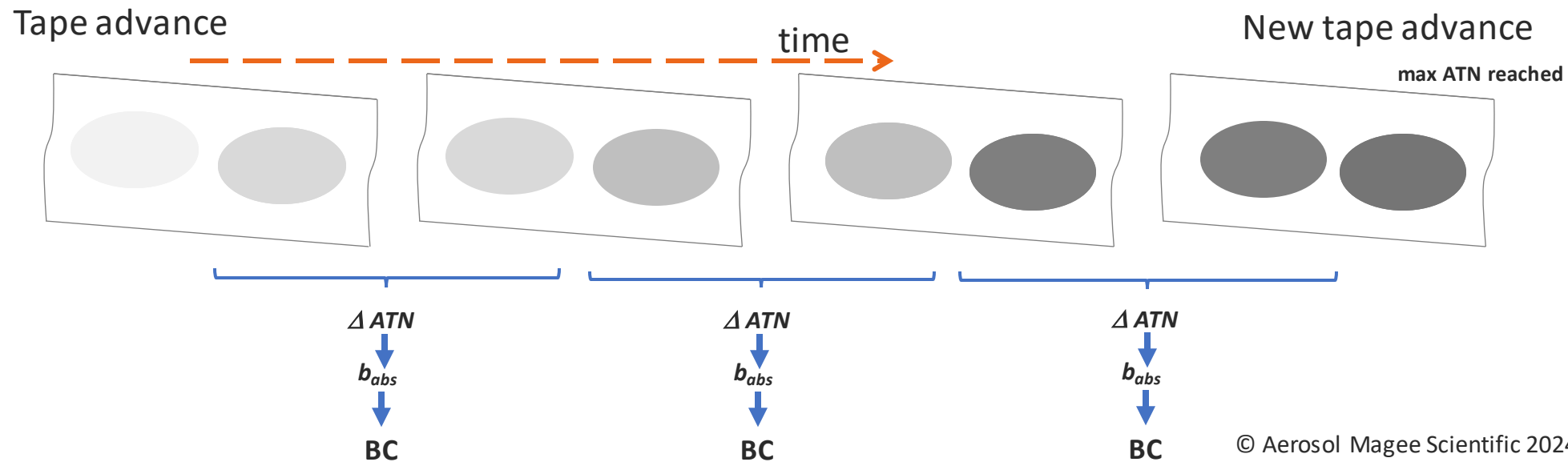

## Loading effect compensation

1. Determination of compensation parameter  $k(\lambda)$
2. Calculation of compensated  $BC$ :

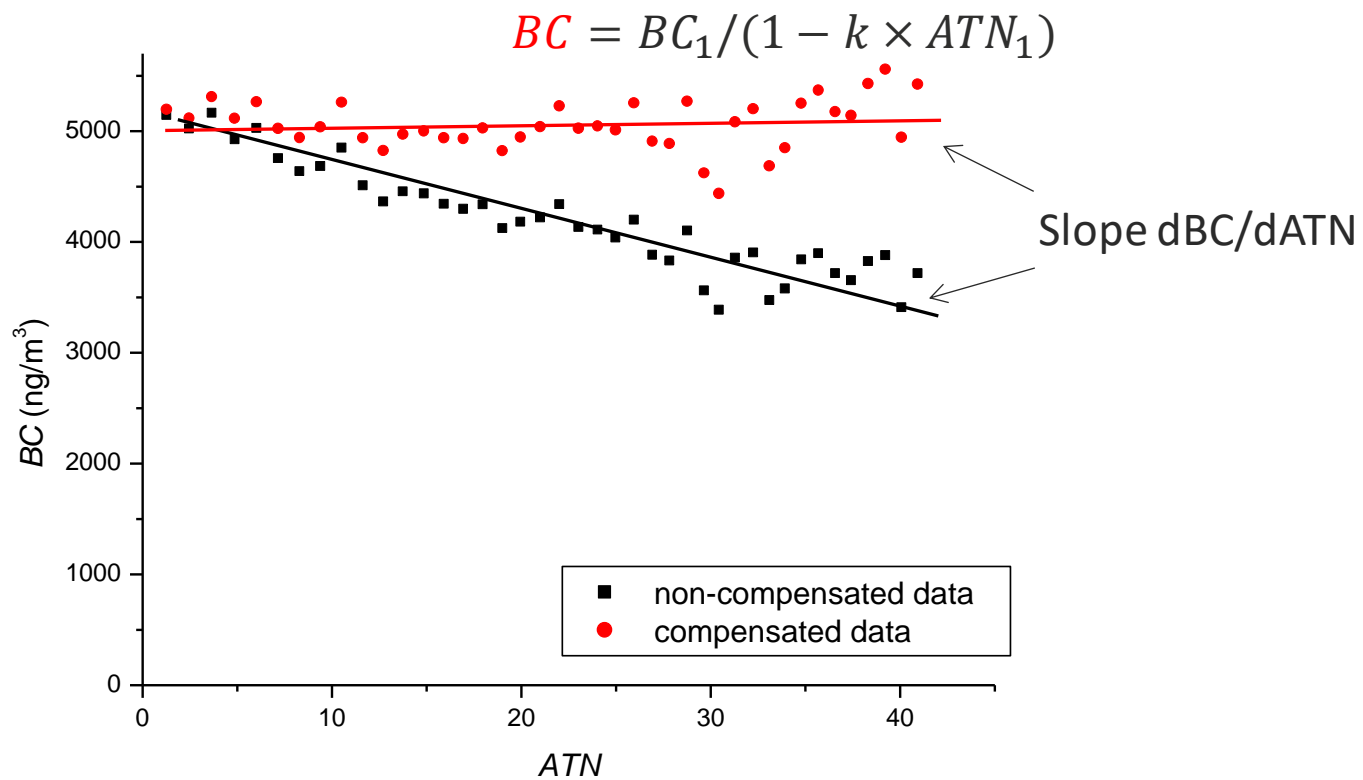

## Loading effect depends on the mixing state

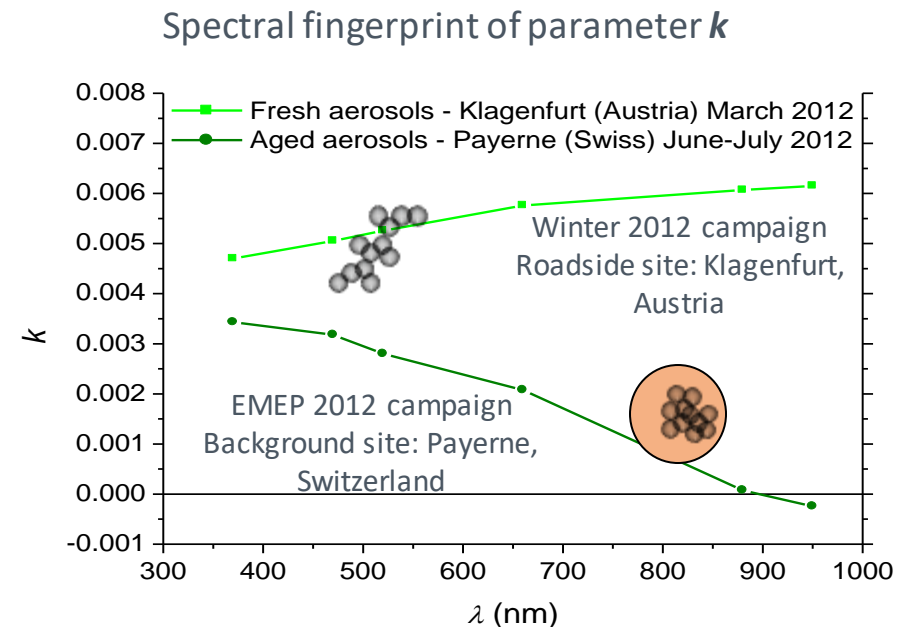
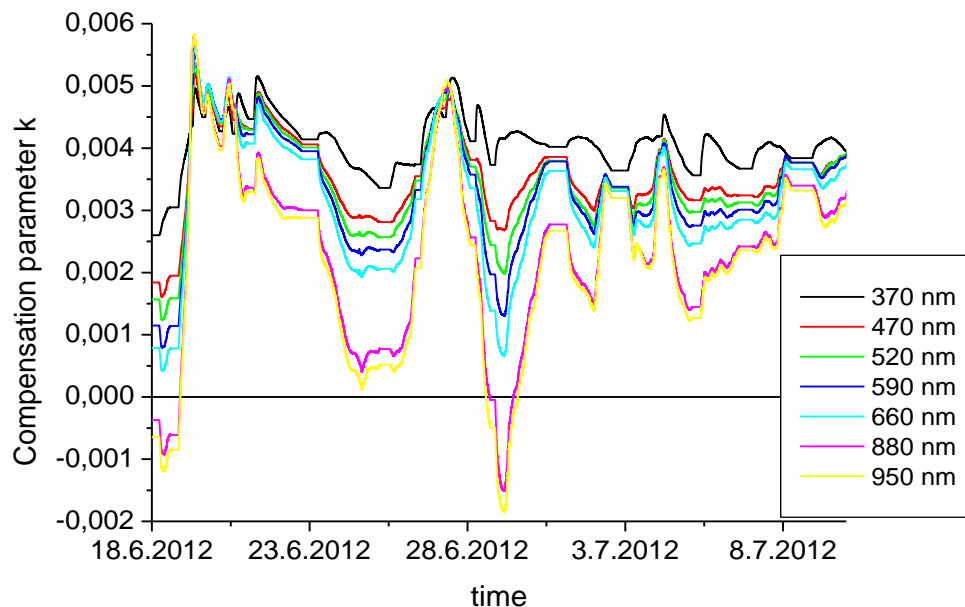

Atmos. Meas. Tech., 10, 1043–1059, 2017  
 www.atmos-meas-tech.net/10/1043/2017/  
 doi:10.5194/amt-10-1043-2017  
 © Author(s) 2017. CC Attribution 3.0 License.



Atmospheric  
Measurement  
Techniques  
Open Access  
EGU

### The filter-loading effect by ambient aerosols in filter absorption photometers depends on the coating of the sampled particles

Luka Drinovec<sup>1,2</sup>, Asta Gregorič<sup>3</sup>, Peter Zotter<sup>4,a</sup>, Robert Wolf<sup>4</sup>, Emily Anne Bruns<sup>4</sup>, André S. H. Prévôt<sup>4</sup>, Jean-Eudes Petit<sup>5,6,b</sup>, Olivier Favez<sup>5</sup>, Jean Sciare<sup>6,7</sup>, Ian J. Arnold<sup>8,c</sup>, Rajan K. Chakrabarty<sup>8,d</sup>, Hans Moosmüller<sup>8</sup>, Agnes Filep<sup>9</sup>, and Griša Močnik<sup>1,2</sup>

[Drinovec, L., Gregorič, A., Zotter, P., Wolf, R., Bruns, E. A., Prévôt, A. S. H., Petit, J. E., Favez, O., Sciare, J., Arnold, I. J., Chakrabarty, R. K., Moosmüller, H., Filep, A., and Močnik, G.: The filter-loading effect by ambient aerosols in filter absorption photometers depends on the coating of the sampled particles, \*Atmos. Meas. Tech.\*, 10, 1043-1059, 2017.](#)

## Loading effect compensation

### Algorithm sensitivity

Temperature → warming up instrument to room temperature

Humidity → no fast humidity & T changes

Input pressure → constant pressure

Setting  $k_{\min}$  &  $k_{\max}$  values:

Default settings:  $-0.005 < k < 0.015$

Expected values:  $0 < k < 0.01$

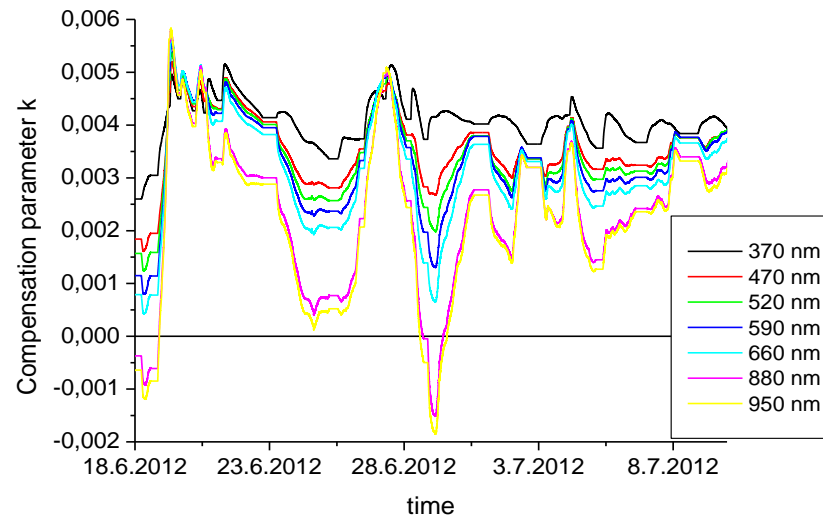



# Basic data presentation

## Reporting BC

Black carbon is by definition reported at 880 nm: **BC6** (compensated values)

- $BC_{bb} = BC6 \times BB\% / 100$
- $BC_{tr} = BC6 - BC_{bb}$

Do not average BB%!

Remove values during the **tape advance** (Status = 1 or 2)

Status;	ContStatus;	DetectStatus;	LedStatus;	ValveStatus;	LedTemp;	BC11;	BC12;	BC1;	BC21;	BC22;
0	0	10	10	0	30	947	2314	3676	1223	2274
0	0	10	10	0	30	1417	2556	5499	1444	2476
1	0	10	10	1100	30	0	0	0	0	0
1	0	10	10	1100	30	0	0	0	0	0
1	0	10	10	1100	30	0	0	0	0	0
1	0	10	10	0	30	0	0	0	0	0
2	0	10	10	0	30	0	0	0	0	0
0	0	10	10	0	30	4049	4621	4062	3199	3844
0	0	10	10	0	30	3989	4630	4014	3217	3830

## Instrument Status – acceptable measurements

The overall status is a **sum** of different status values.

Status	Description	
0	Measurement	
4	Flow out of range	Check flow & flow ratio
8	Check flow status history	Check flow
12	Flow low/high & check flow status history	Check flow
128	Tape warning	
256	Tape last warning	
8192	Connection error	Check external device connection
32768	CF card	
65535	Database full	

## Data treatment – how to present measured data?

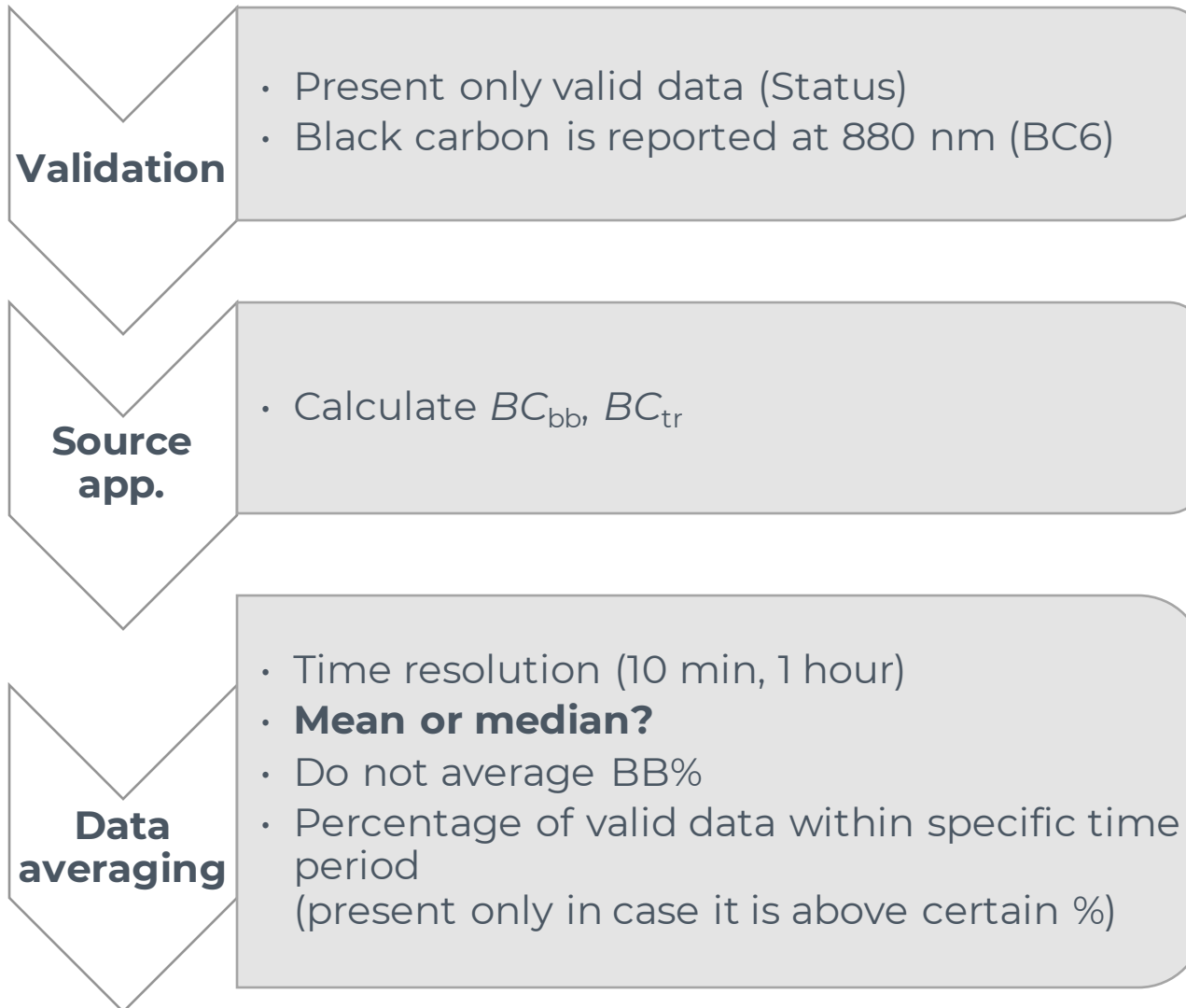

## Mean or median?

When reporting measurements at 1h time resolution: **median** values (Q1, Q3)

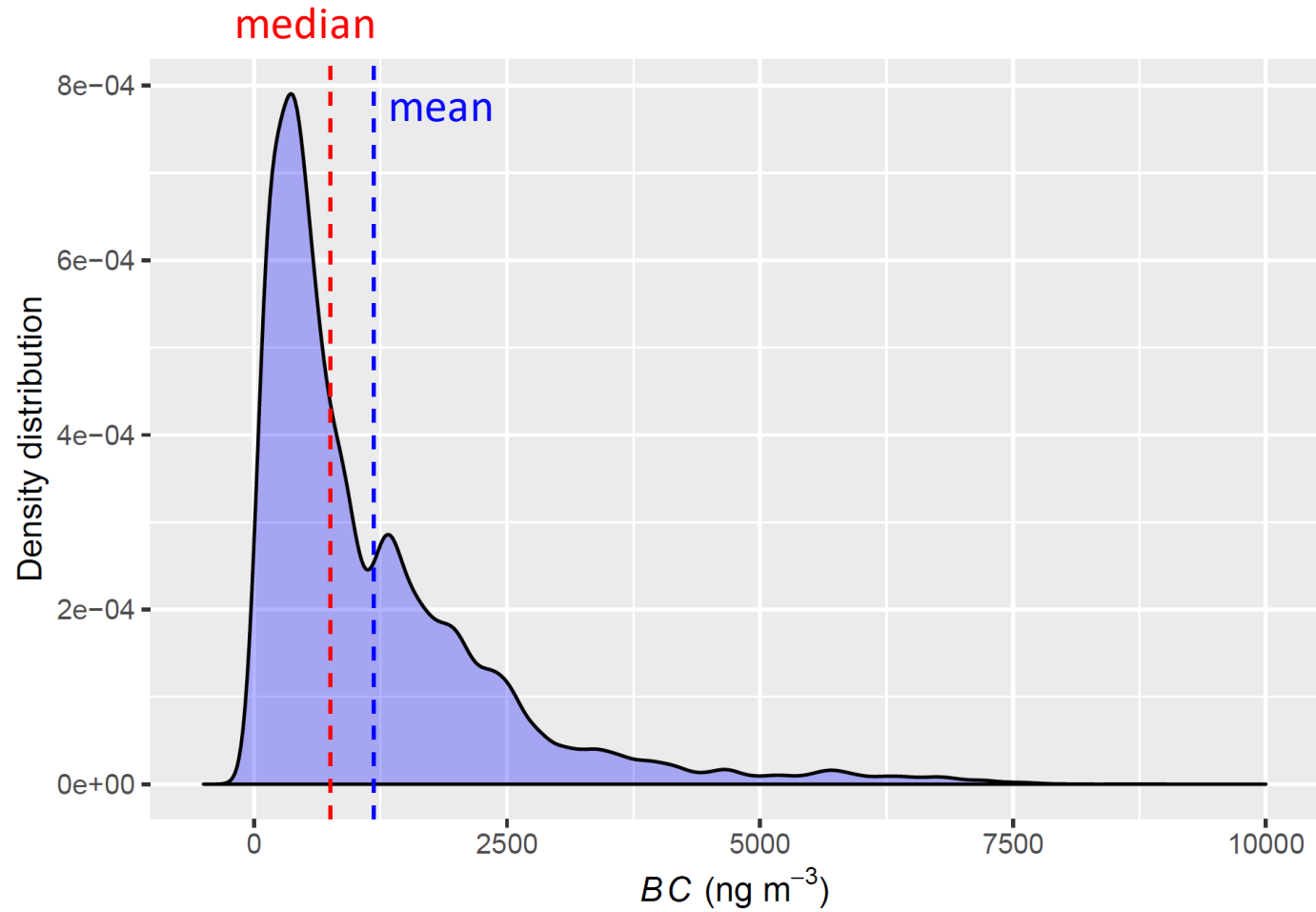

# How to treat noisy data

Do not remove negative values! It can bias your results.

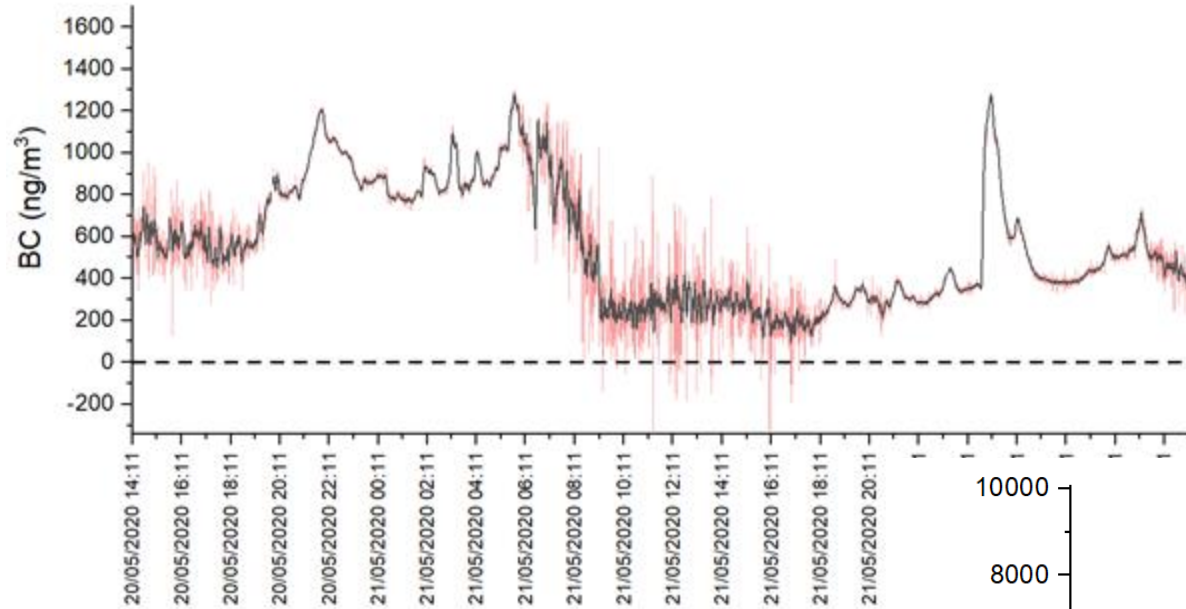

BC is very heterogeneously distributed  $\rightarrow$   
real measurement or noise?

Local traffic contribution, clean environment

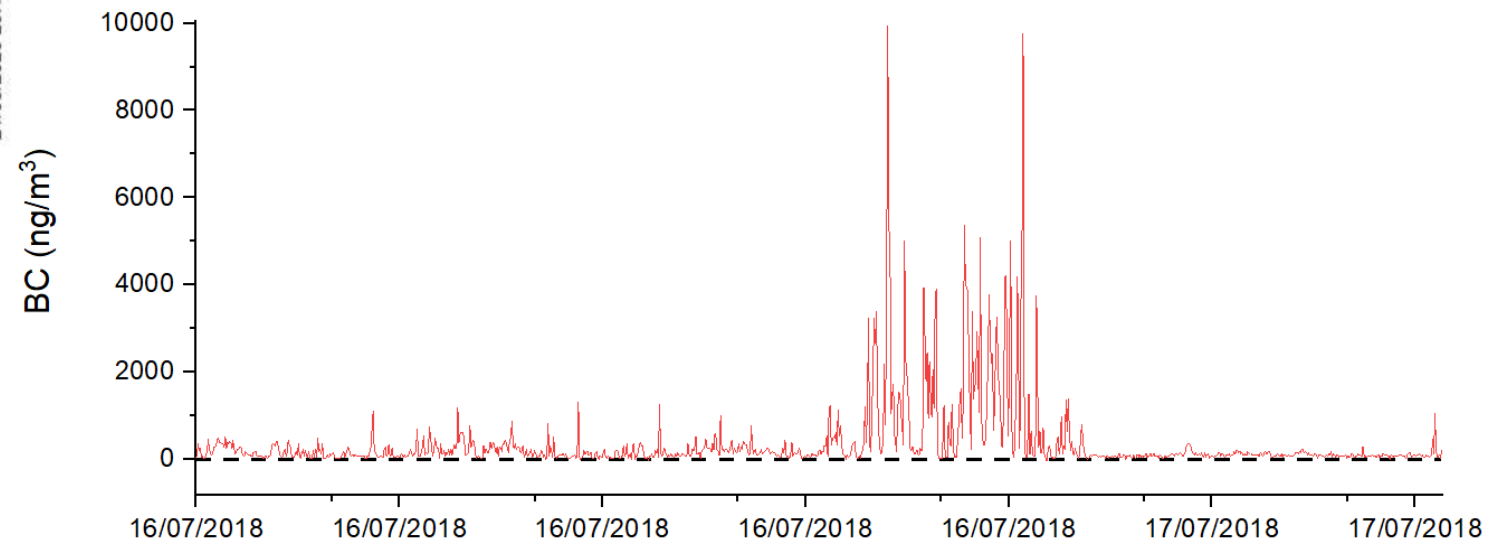

# Aethalometer intercomparison

Usually tested @  $< 50 \mu\text{g}/\text{m}^3$

For higher concentrations to avoid frequent TA:

- Reduce flow to 2 LPM
- Increase Max ATN to 150

<https://doi.org/10.5194/amt-2020-344>  
Preprint. Discussion started: 28 August 2020  
© Author(s) 2020. CC BY 4.0 License.



## Intercomparison and characterization of 23 Aethalometers under laboratory and ambient air conditions: Procedures and unit-to-unit variabilities

Andrea Cuesta-Mosquera<sup>1</sup>, Griša Močnik<sup>2,3,4</sup>, Luka Drinovec<sup>2,3</sup>, Thomas Müller<sup>1</sup>, Sascha Pfeifer<sup>1</sup>, María Cruz Minguillón<sup>5</sup>, Briel Björn<sup>6</sup>, Paul Buckley<sup>7</sup>, Vadimas Dudoitis<sup>8</sup>, Javier Fernández-García<sup>9</sup>, María Fernández-Amado<sup>10</sup>, Joel Ferreira De Brito<sup>11</sup>, Harald Flentje<sup>6</sup>, Eimear Heffernan<sup>7</sup>, Nikolaos Kalivitis<sup>12</sup>, Athina-Cerise Kalogridis<sup>13</sup>, Hannes Keernik<sup>14,15</sup>, Luminita Marmureanu<sup>16</sup>, Krista Luoma<sup>17</sup>, Angela Marinoni<sup>18</sup>, Michael Pikridas<sup>19</sup>, Gerhard Schauer<sup>20</sup>, Norbert Serfozo<sup>21</sup>, Henri Servomaa<sup>22</sup>, Gloria Titos<sup>23</sup>, Jesús Yus-Diez<sup>2,24</sup>, Natalia Ziola<sup>25</sup>, Alfred Wiedensohler<sup>1</sup>

<https://amt.copernicus.org/preprints/amt-2020-344/>

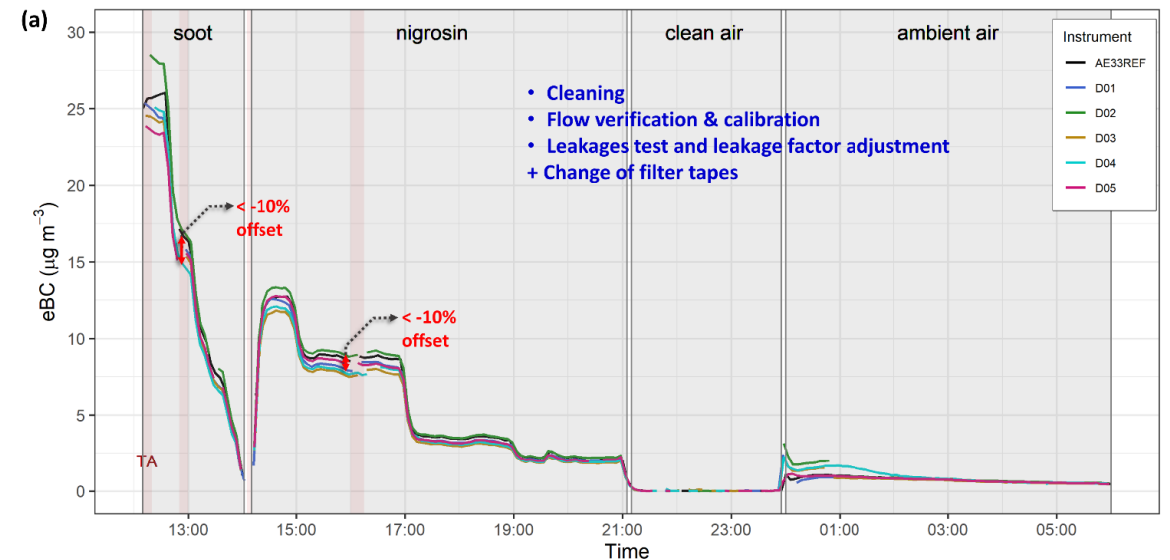

## Traffic & biomass burning contribution to BC

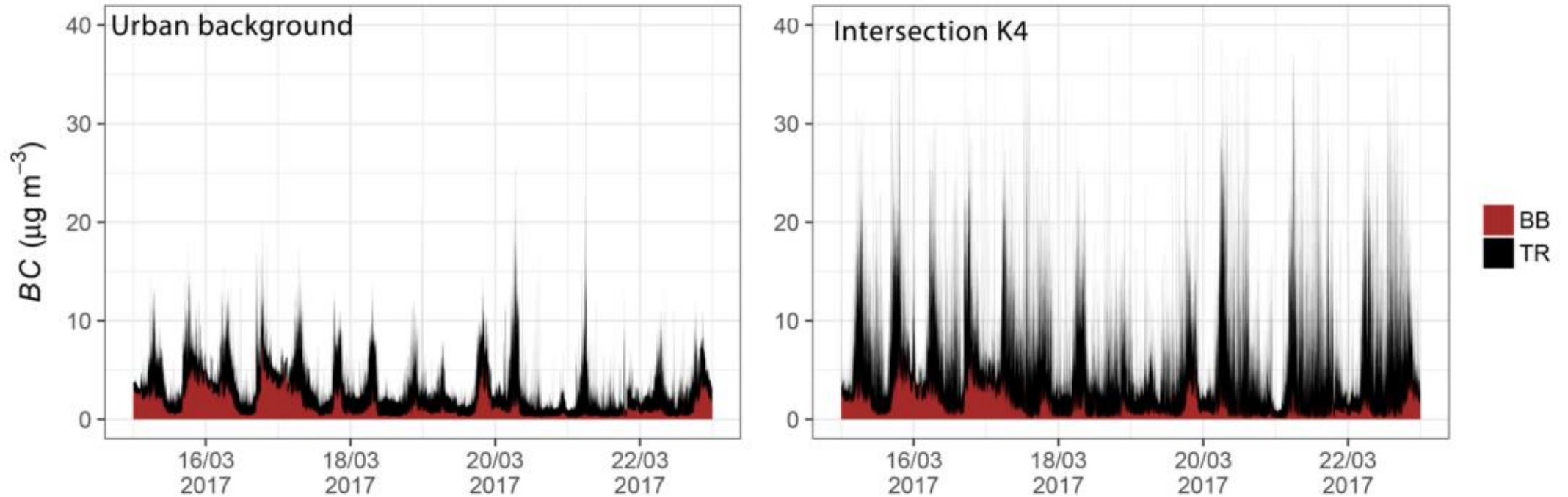

Jereb et al.: Exposure to Black Carbon during Bicycle Commuting—Alternative Route Selection, *Atmosphere*, 9, 2018.



## When in doubt ..

- contact us at [support@aerosolmageesci.com](mailto:support@aerosolmageesci.com)
- register to our User's group at <https://aerosolmageesci.com/group/>

To gain access to different information related to our products, including specification sheets, manuals, white papers, photo and video material, publications, and software updates.



## **Advanced data analyses**

## Source apportionment model - limitations

Aethalometer model apportions BC to traffic and biomass burning sources based on the “colour” of aerosol sample.

### Model assumptions/limitations:

- **Only 2 sources:** biomass & fossil fuel
- **Known characteristic AAE\*** for pure biomass smoke and pure fossil fuel source



Fine tuning the characteristic  $AAE_{TR}$  and  $AAE_{BB}$  to adjust the model to local conditions.

$$AAE_{TR} \approx 1 \quad (0.9 - 1.1)$$

$$AAE_{BB} \approx 1.7 - 3.5$$



# Absorption Ångström exponent

- **AAE**: Wavelength dependence of optical absorption.
- It has to be calculated from **compensated** data. Uncompensated data result in biased AAE!

$$b_{abs-i} [Mm^{-1}] = BC_i \times MAC_i / 1000$$

$$AAE = \frac{\ln \left( \frac{b_{abs-470}}{b_{abs-950}} \right)}{\ln \left( \frac{950}{470} \right)}$$

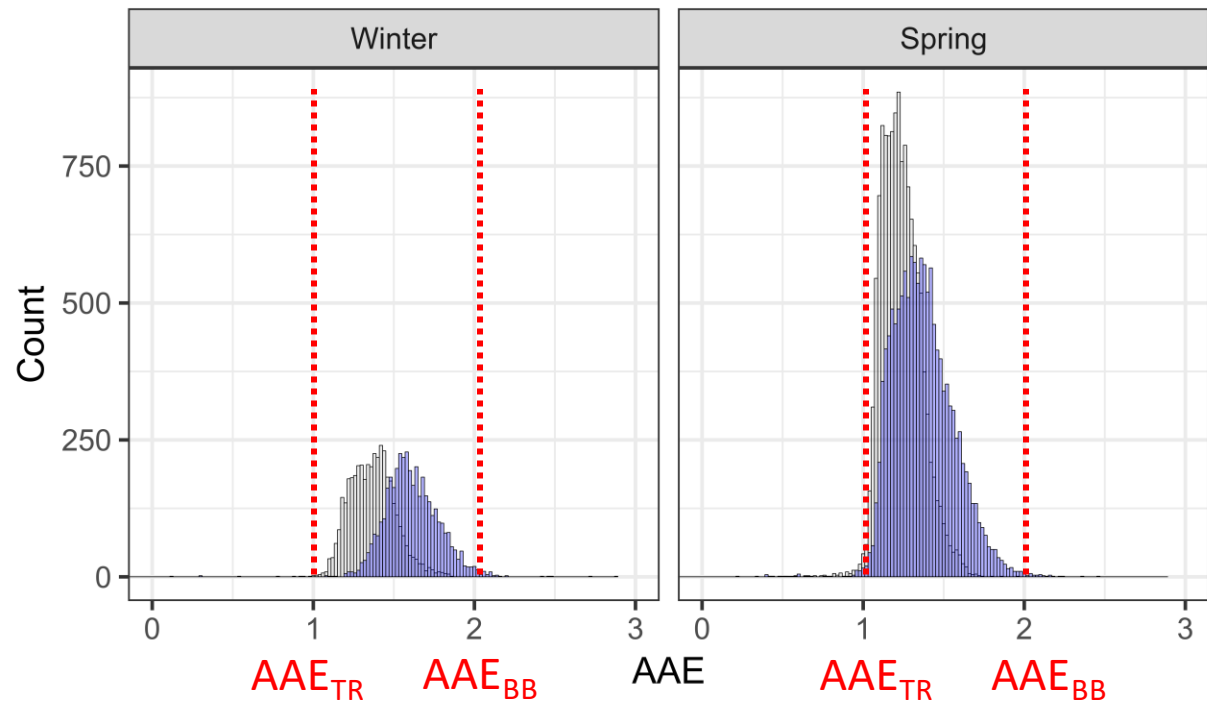

Location



AEROSOL  
MAGEE SCIENTIFIC

**Basic equations**

Basic equation  $BC = \frac{S \times \Delta \ln}{F \times \Delta t \times \sigma}$

Sigma & multiple scattering parameter  $\sigma_{\text{filter}} = \sigma_{\text{air}} \times C$  (Hess et al., 2002)  
 $C = 1.38$  (Teflon, M8060)

Loading effect compensation  $BC_{\text{comp}} = BC / (1 - R \times ATN)$

Measured leakage  $F_{\text{le}} = F_{\text{meas}} \times (1 - C)$   
Leakage factor ( $\approx 0.01$ ) (Teflon, M8060)

Final equation  $BC = \frac{S \times \Delta \ln}{F_{\text{le}}(1 - C) \times \sigma_{\text{air}} \times C_{\text{air}} \times (1 - R \times ATN) \times \Delta t}$

## Fine tuning source app. model – tracers

### Recalculation to new AAE pair

$$\frac{b_{abs}(470\text{ nm})_{ff}}{b_{abs}(950\text{ nm})_{ff}} = \left(\frac{470}{950}\right)^{-\alpha_{ff}},$$

$$\frac{b_{abs}(470\text{ nm})_{bb}}{b_{abs}(950\text{ nm})_{bb}} = \left(\frac{470}{950}\right)^{-\alpha_{bb}},$$

$$b_{abs}(470\text{ nm}) = b_{abs}(470\text{ nm})_{ff} + b_{abs}(470\text{ nm})_{bb}$$

$$b_{abs}(950\text{ nm}) = b_{abs}(950\text{ nm})_{ff} + b_{abs}(950\text{ nm})_{bb}$$

Source apportionment results can be compared with other methods:

- **C-14** analyses (e.g. Zotter et al., 2015)
- **K, levoglucosan** (biomass tracers)
- **NO<sub>x</sub>** (traffic tracers)



# CAAT – Carbonaceous Aerosol Analyses Tool

## CAAT

The CAAT application is a **software tool** for analyzing data related to AE33, AE43 and TCA08 instruments.

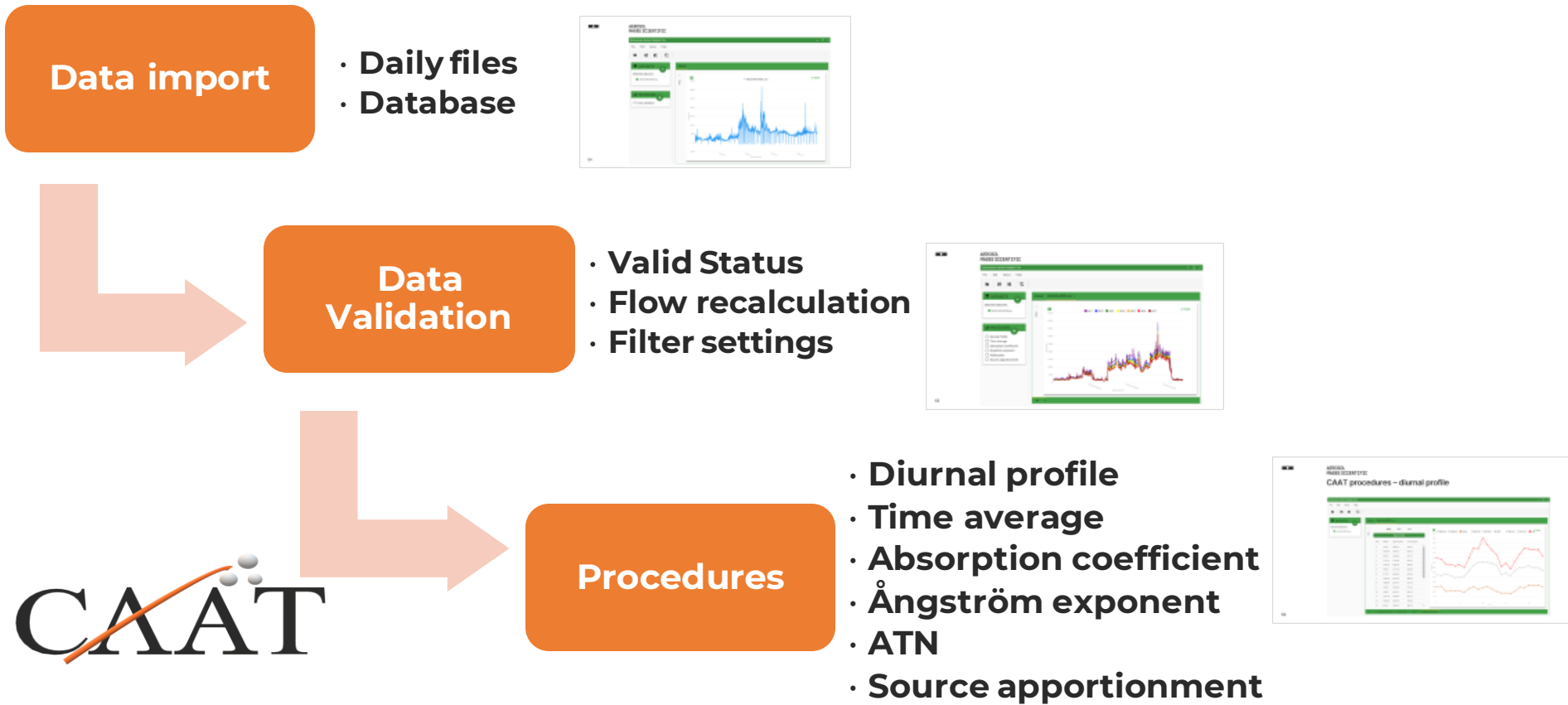

# AEROSOL MAGEE SCIENTIFIC

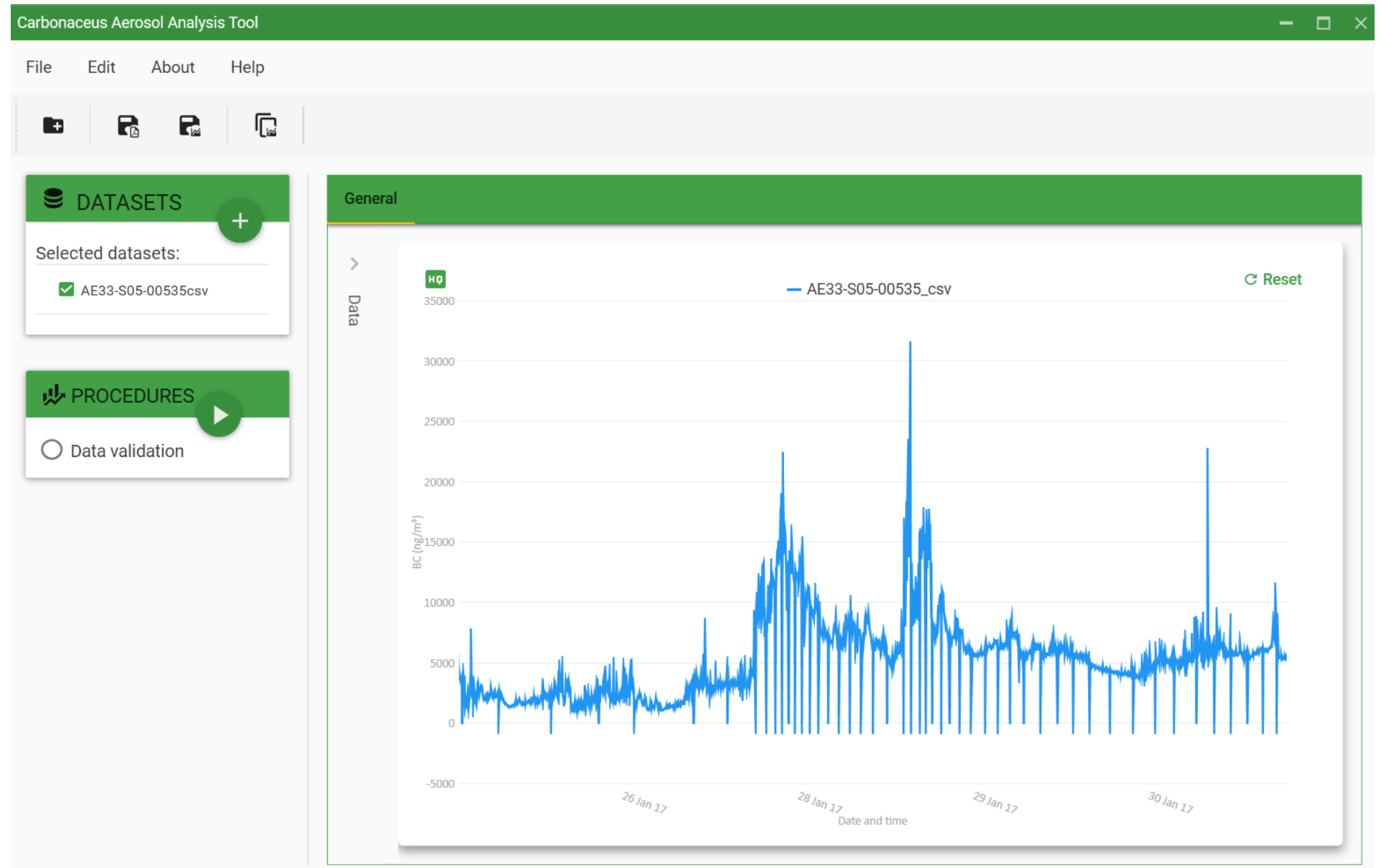

# AEROSOL MAGEE SCIENTIFIC

Carbonaceous Aerosol Analysis Tool

File Edit About Help

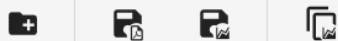

## DATASETS

Selected datasets:

AE33-S05-00535csv

## PROCEDURES

- Diurnal Profile
- Time Average
- Absorption Coefficient
- Ångström exponent
- Attenuation
- Source Apportionment

General AE33-S05-00535\_csv x

Data

HQ

BC1  BC2  BC3  BC4  BC5  BC6  BC7

Reset

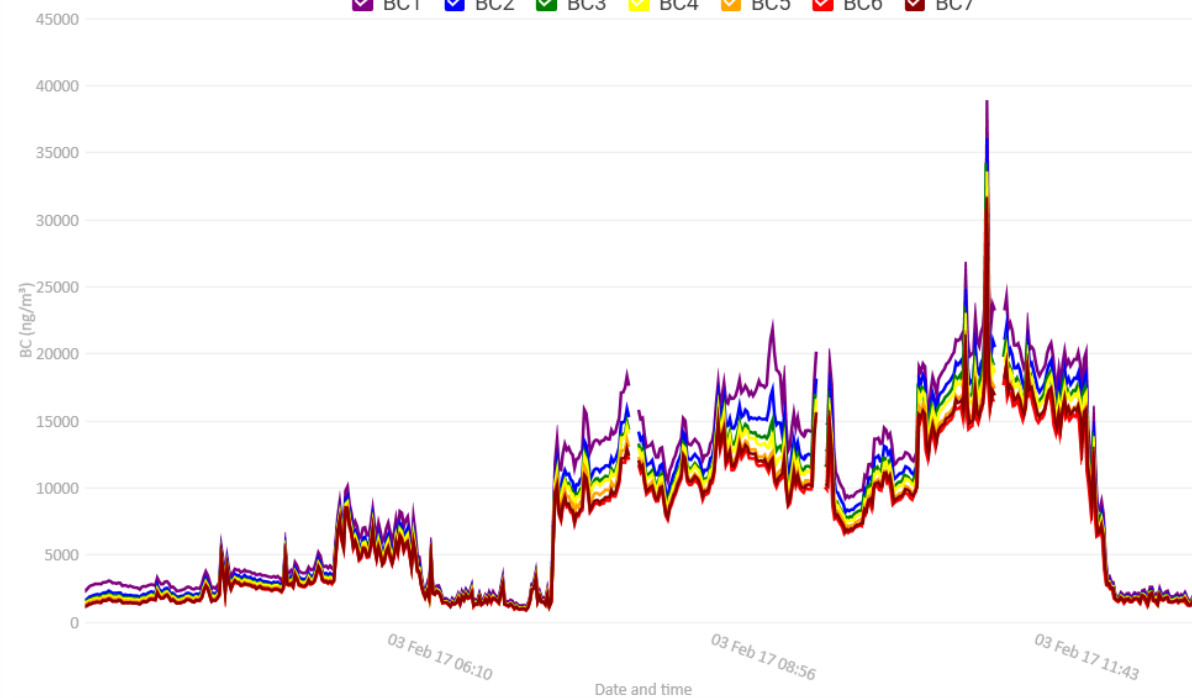

BC x

# CAAT procedures – diurnal profile

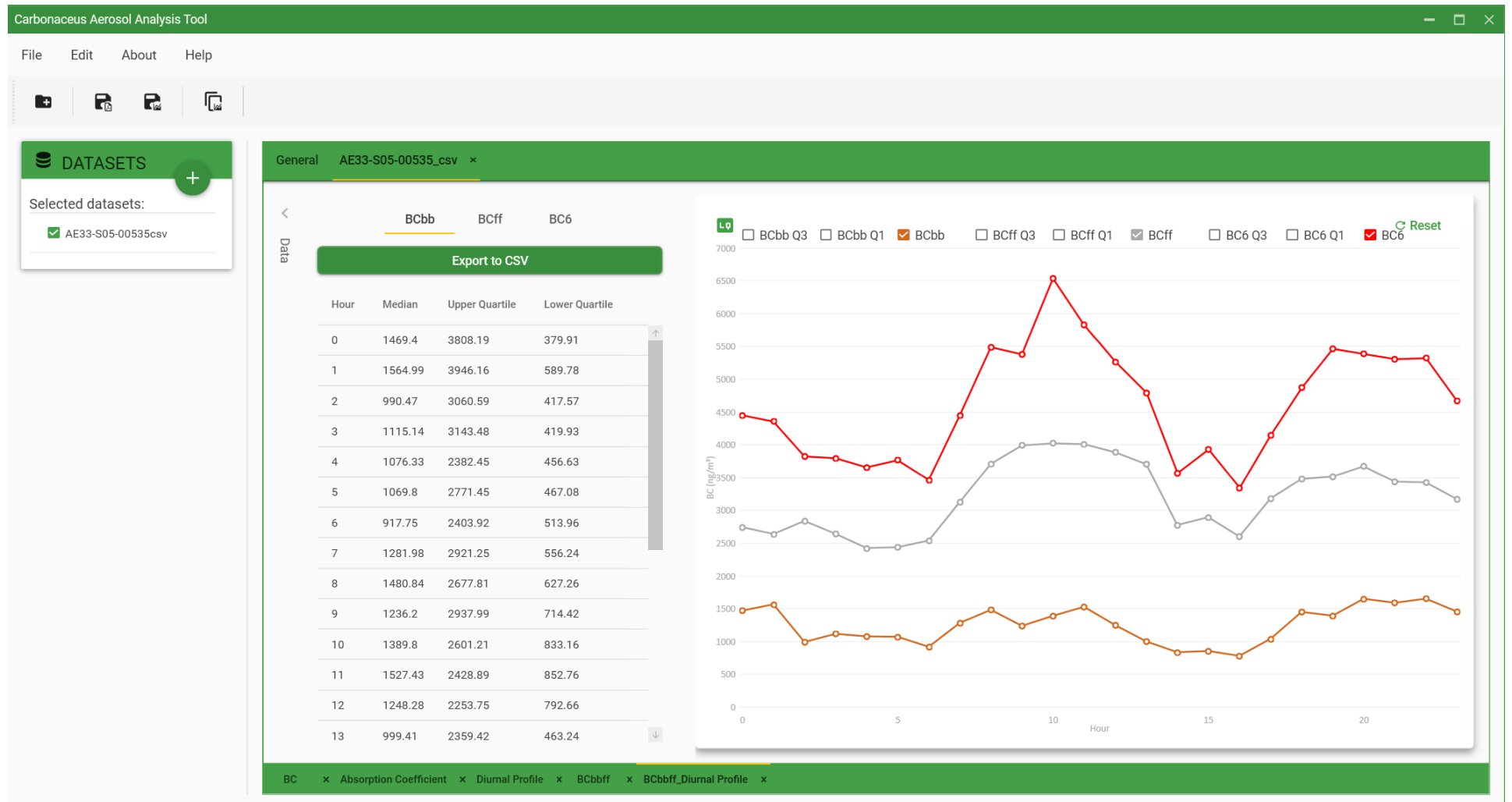

## Basic equations

Basic equation

$$BC = \frac{S \times \Delta atn}{F \times \Delta t \times \sigma}$$

Sigma & multiple  
scattering parameter

$$\sigma_{filter} = \sigma_{air} \times C \text{ (Weingartner et al., 2003)}$$

$$C = 1.39 \text{ (Teflon, M8060)}$$

Loading effect  
compensation

$$BC_{comp} = BC / (1 - k \times ATN)$$

Measured leakage

$$F_{in} = F_{out} \times (1 - \zeta)$$

$$\text{Leakage factor } \zeta = 0.01 \text{ (Teflon, M8060)}$$

Final equation

$$BC = \frac{S \times \Delta atn_1}{F_1 (1 - \zeta) \times \sigma_{air} \times C_{teflon} \times (1 - k \times ATN_1) \times \Delta t}$$

## Analytical performance – AE33

Parameter	Description / procedure	Value
Resolution	Resolution of the AE33 in terms of ng/m <sup>3</sup> of BC depends on the resolution of raw signals of the Reference, Sens1 and Sens2 sensors.	<b>1 ng/m<sup>3</sup></b> @ ATN=0, 5 LPM, 1 s timebase
Limit of detection	the smallest absolute amount of change that can be detected by a measurement. <b>mean value of clean air measurement + 2σ</b>	700 ng/m <sup>3</sup> @ 5 LPM, 1s <b>30 ng/m<sup>3</sup></b> @ 5 LPM, 1 min
Precision	The closeness of agreement between independent measurement results obtained under stipulated conditions.	< 10 %
Measurement uncertainty	Cumulative uncertainty for independent variables: - C: <b>20%</b> - MAC (influenced by lensing effect): <b>15%</b> - Instrument variability: <b>8%</b> - Cross sensitivity to scattering : <b>5%</b>	Background station: <b>27%</b>

## AE33/AE36 – Multiple scattering enhancement factor C

Savadkoohi M. et al., The variability of mass concentrations and source apportionment analysis of equivalent black carbon across urban Europe

- Harmonized methods ensure consistency of eBC comparisons
- Source apportionment (AAE = 1 and 2; eBC<sub>T</sub> decreasing over decades, eBC<sub>RC</sub> constant)
- Long term trends:
  - a constant statistically significant **decreasing trend of eBC from TR** was detected at all sites during the observation period (EURO5 and economic crisis in 2008)
  - eBC<sub>RC</sub> emissions **from residential and commercial sources remained constant**

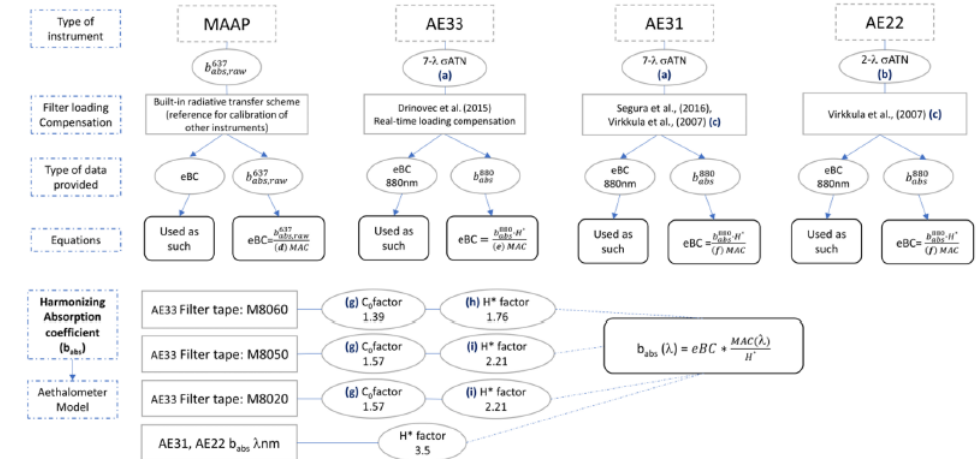

Scheme by which to process corrected and harmonized eBC mass concentrations and absorption coefficients from the attenuation coefficient.

$$C = C_0 \times H^*$$

$$C = 1.39 \times 1.76 = 2.45$$